

[Http://www.parsun.com.cn](http://www.parsun.com.cn)

PARSUN

百勝

零件目錄

PARTS CATALOGUE

F25

BM

蘇州百勝動力機器有限公司

SUZHOU PARSUN POWER MACHINE CO., LTD

目次

CONTENTS

托架 1	1 ~ 3
BRACKET 1	1 ~ 3
托架 2	4 ~ 5
BRACKET 2	4 ~ 5
操舵系统	6 ~ 7
STEERING	6 ~ 7
水上装置壳体	8
UPPER CASING	8
油底壳组件	9
OIL PAN	9
底罩	10 ~ 11
BOTTOM COWLING	10 ~ 11
控制系统	12 ~ 13
CONTROL SYSTEM	12 ~ 13
水下装置壳体和驱动系统 1	14 ~ 16
LOWER CASING & DRIVE 1	14 ~ 16
水下装置壳体和驱动系统 2	17
LOWER CASING & DRIVE 2	17
电气	18
ELECTRICAL	18
进气系统	19 ~ 20
INTAKE	19 ~ 20
气缸和曲轴箱	21 ~ 23
CYLINDER & CRANKCASE	21 ~ 23
曲轴和活塞	24
CRANKSHAFT & PISTON	24
阀门	25
VALVE	25
油泵	26
OIL PUMP	26
燃油系统	27 ~ 28
FUEL	27 ~ 28
起动机	29 ~ 31
STARTER	29 ~ 31
顶罩组件	32
TOP COWLING ASSY	32
燃油箱	33
FUEL TANK	33
附录1(修理件)	34 ~ 35
APPENDIX 1 (REPAIR KIT)	34 ~ 35
附录2(修理件)	36 ~ 37
APPENDIX 2 (REPAIR KIT)	36 ~ 37

零部件名称:

托架1

PARTS NAME:

BRACKET 1

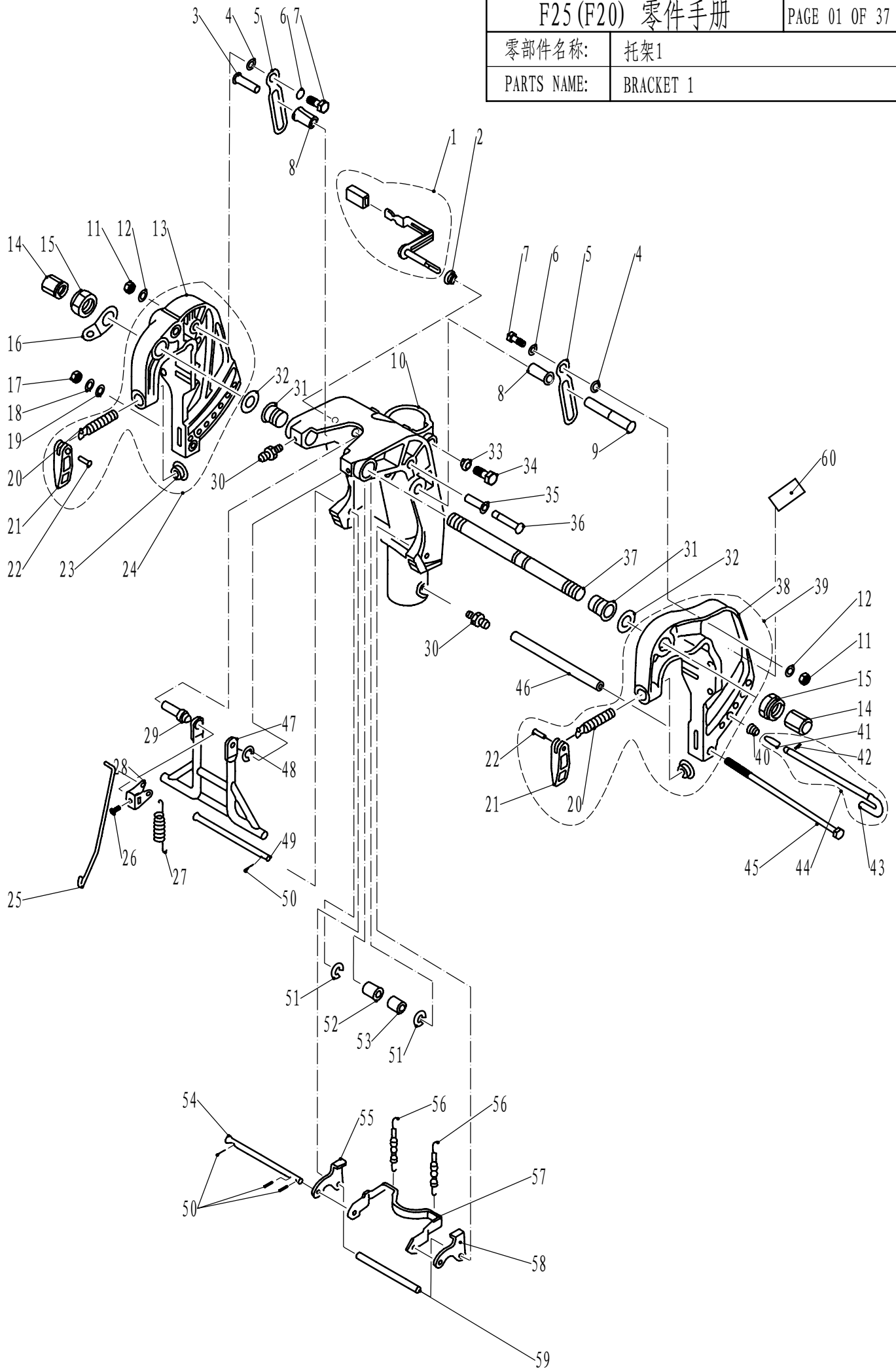

零部件名称:

托架1

PARTS NAME:

BRACKET 1

SN. 参照号码	PART NO. 零件编号	DESCRIPTION 零件名称(中文)	DESCRIPTION 零件名称(英文)	QTY 数量				REMARKS 备注
1	F25-01010312	角度锁紧手柄组件	TILT CLAMP HANDLE ASSY	1				
2	F25-01010311	锁紧手柄衬圈	WASHER	1				
3	F25-01010318	制动板销轴(短)	PIN, DETENT	1				
4	F25-01010009	尼龙垫圈	WASHER, NYLON	2				
5	F25-01010321	倾斜制动板	PLATE, TILT DETENT	2				
6	F25-01010008	波形垫圈	WASHER, WAVE	2				
7	F25-01010007	扁六角轴位螺钉	SCREW, PROLATE HEXAGON	2				
8	F25-01010319	销轴尼龙衬套(高)	GASKET, NYLON	2				
9	F25-01010322	制动板销轴(长)	PIN, DETENT	1				
10	F25-01010301	旋转支架	BRACKET, ROTARY	1				L
	F25-01010301S	旋转支架	BRACKET, ROTARY	1				S
11	GB/T6182-M8	非金属嵌件六角锁紧螺母M8	LOCKNUT M8	2				
12	F25-01010010	厚垫片8	THICK WASHER	2				
13	F25-01010201	右夹紧托架	BRACKET, RIGHT	1				
14	F25-01010011	塑料装饰螺母	NUT, PLASTIC	2				
15	F15-01010007	托架夹紧螺母	NUT, SELF-LOCKING	2				
16	F25-01010004	双孔固定板	PLATE, TWO HOLE	1				
17	GB/T6170-M8	六角螺母M8	NUT M8	1				
18	GB/T93-8	弹簧垫圈8	WASHER, SPRING 8	1				
19	GB/T97.1-8	平垫圈8	WASHER 8	1				
20	F25-01010104	舰板夹紧螺杆	SCREW, CLAMP	2				
21	F25-01010102	舰板夹紧手柄	CLAMP HANDLE	2				
22	F25-01010103	舰板夹紧手柄铆钉	RIVET	2				
23	F4-01010003	舰板夹紧圆盘	CLAMP PLATE	2				
24	F25-01010200	右夹紧托架组件	RIGHT BRACKET ASSY	1				
25	F25-01010315	角度锁紧支架连杆	ROD, BRACKET	1				
26	GB/T818-M5x6	十字槽盘头螺钉M5×6	SCREW, PAN HEAD M5x6	1				
27	F25-01010314	角度支撑架拉簧	SPRING, TENSION	1				
28	F25-01010313	角度定位件	LEVER, ANGLE ORIENTATION	1				
29	F25-01010309	锁紧手柄轴套	BUSHING, HANDLE	1				
30	GB/T7940.1-M6	直通式压注油杯M6	OIL, CUP M6	3				
31	F25-01010002	螺管尼龙衬套	BUSH, NYLON	2				
32	F25-01010003	螺管垫圈	WASHER	2				
33	F25-01010302	锁紧螺栓密封圈	WASHER, SEAL	1				
34	F25-01010303	六角凸缘螺栓M8×20	HEXAGON BOLT	1				
35	F25-01010317	销轴衬套	BUSH, PIN	1				
36	F25-01010316	角度支撑架销轴	SHAFT, ANGLE BRACKET	1				
37	F15-01010001	夹紧托架双头螺管	BOLT, CLAMP BRACKET	1				
38	F25-01010101	左夹紧托架	BRACKET, LEFT	1				
39	F25-01010100	左夹紧托架组件	LEFT BRACKET ASSY	1				
40	F25-01010403	锥形弹簧	CONICAL SPRING	1				
41	F25-01010402	防脱落支脚	PLATE, PREVENT DESQUAMATION	1				
42	GB/T879.2-3x10	弹性圆柱销3×10	PIN, SPRING 3x10	1				

零部件名称: 托架 2

PARTS NAME: BRACKET 2

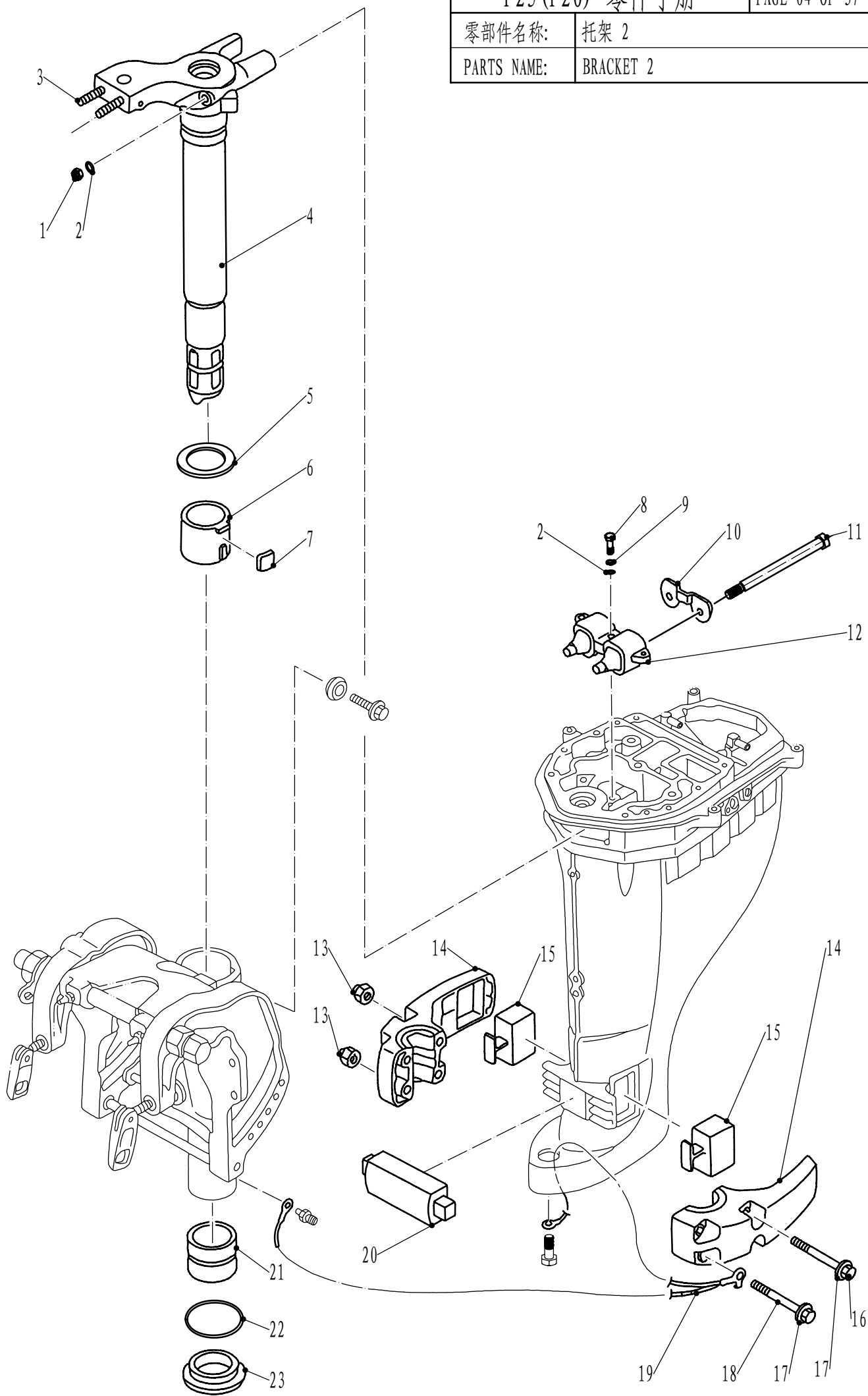

零部件名称: 操舵系统

PARTS NAME: STEERING

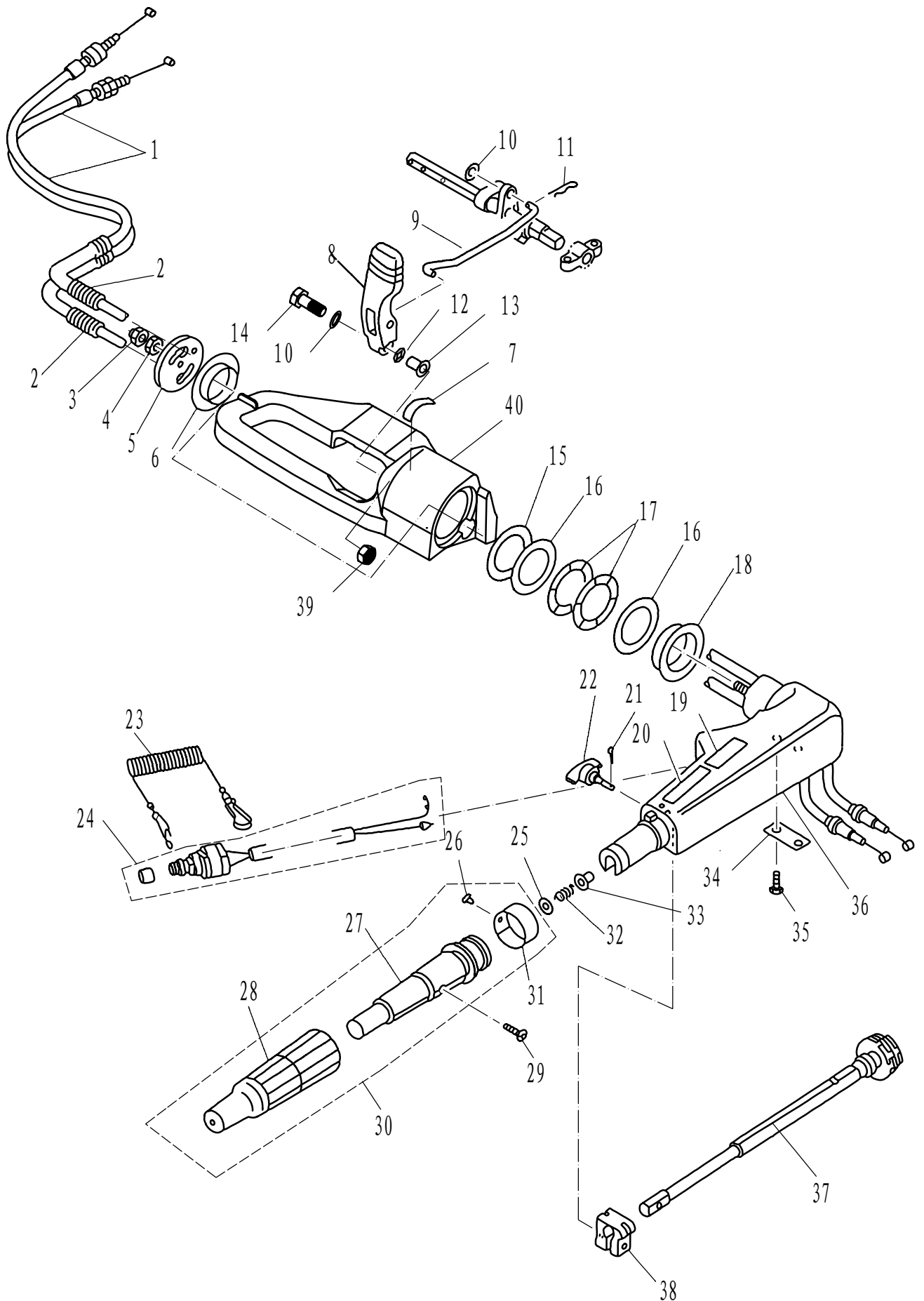

零部件名称:

水上装置壳体

PARTS NAME:

UPPER CASING

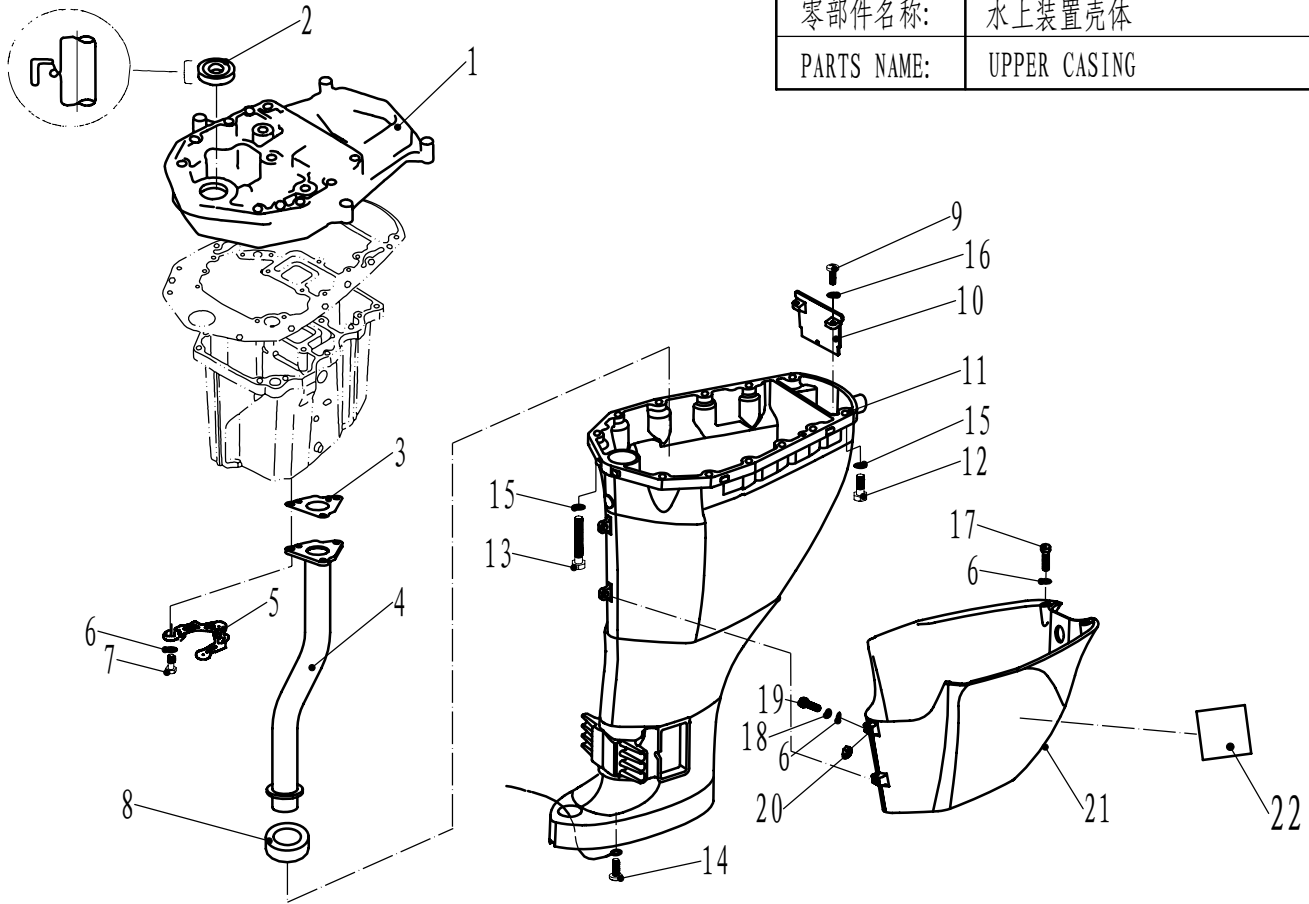

SN. 参照号码	PART NO. 零件编号	DESCRIPTION 零件名称 (中文)	DESCRIPTION 零件名称 (英文)	QTY 数量				REMARKS 备注
1	F25-02010001	排气歧管座	GUIDE EXHAUST	1				
2	F25-02010002	排气歧管座油封	OIL SEAL	1				
3	F25-02000011	排气导管垫	GASKET, EXHAUST PIPE	1				
4	F25-02020000	排气导管组件	EXHAUST PIPE ASSY	1				L
	F25-02020000S	排气导管组件	EXHAUST PIPE ASSY	1				S
5	F25-02000012	V形垫板	PLATE, "V"	1				
6	GB/T97.1-6	平垫圈6	WASHER 6	7				
7	GB/T5782-M6x50	六角螺栓M6x50	BOLT M6x50	3				
8	F25-02000014	排气管密封圈	SEAL, EXHAUST PIPE	1				
9	GB/T818-M5x16	十字槽盘头螺钉M5x16	SCREW, PAN HEAD M5x16	2				
10	F25-02000003	排气隔板	CLAPBOARD, EXHAUST	1				
11	F25-02000001	水上装置壳体	UPPER CASING	1				L
	F25-02000001S	水上装置壳体	UPPER CASING	1				S
12	GB/T5783-M8x30	六角螺栓M8x30	BOLT M8x30	4				
13	GB/T5782-M8x80	六角螺栓M8x80	BOLT M8x80	8				
14	GB/T818-M6x10	十字槽盘头螺钉M6x10	SCREW, PAN HEAD M6x10	1				
15	GB/T97.1-8	平垫圈8	WASHER 8	12				
16	GB/T97.1-5	平垫圈5	WASHER 5	2				
17	GB/T5783-M6x14	六角螺栓M6x14	BOLT M6x14	2				
18	GB/T93-6	弹性垫圈6	WASHER, SPRING	2				
19	GB/T818-M6x25	十字槽盘头螺钉M6x25	SCREW, PAN HEAD M6x25	2				
20	GB/T6170-M6	六角螺母M6	NUT M6	2				
21	F25-00000200	水上装置罩壳	MANTLE, UPPER CASING	1				
22	F15-12000004	标贴4	MARK 4	1				

零部件名称:

油底壳组件

PARTS NAME:

OIL PAN

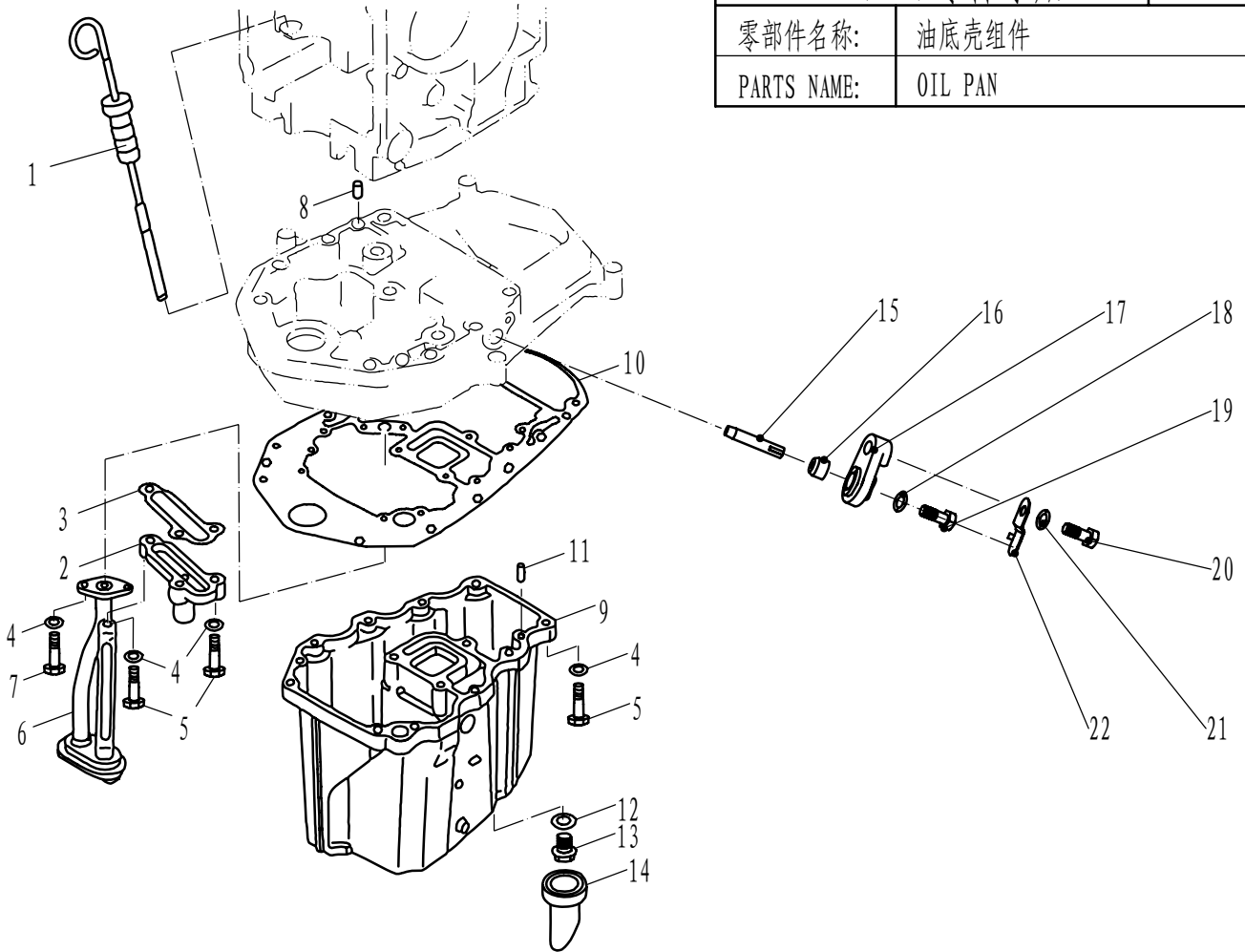

SN. 参照号码	PART NO. 零件编号	DESCRIPTION 零件名称 (中文)	DESCRIPTION 零件名称 (英文)	QTY 数量					REMARKS 备注
1	F25-00000100	机油尺组件	PLUG, OIL LEVEL	1					
2	F25-02010100	溢流阀组件	RELIEF VALVE AUY	1					
3	F25-02010006	溢流阀垫片	GASKET, RELIEF VALVE	1					
4	GB/T97.1-6	平垫圈6	WASHER 6	15					
5	GB/T5783-M6x25	六角螺栓M6x25	HEXAGON BOLT M6x25	13					
6	F25-02010200	粗滤器组件	STRAINER, OIL	1					
7	GB/T5783-M6x16	六角螺栓M6x16	HEXAGON BOLT M6x16	2					
8	F25-00000014	定位销8x12	PIN, DOWEL	2					
9	F25-02000006	油底壳	OIL SUMP	1					
10	F25-02010007	排气歧管座垫	HEXAGON BOLT	1					
11	F15-00000006	定位销6x12	PIN, DOWEL	2					
12	F15-04000003	放油螺塞垫片	GASKET	1					
13	F15-04000002	放油螺塞	BOLT, OIL DRAIN	1					
14	F25-02000007	放油口胶套	JACKET, OIL DRAIN	1					
15	F25-02010005	阳极	ANODE	1					
16	F15-07010009	阳极密封圈	SEAL, ANODE	1					
17	F15-07010011	阳极盖板	COVER , ANODE	1					
18	GB/T97.1-5	平垫圈5	WASHER 5	1					
19	GB/T5783-M5x12	六角螺栓M5x12	BOLT M5x12	1					
20	GB/T5783-M6x20	六角螺栓M6x20	BOLT M6x20	1					
21	GB/T97.1-6	平垫圈6	WASHER 6	1					
22	F15-07010012	阳极锁止片	PLATE , ANODE	1					

零部件名称:

底罩

PARTS NAME:

BOTTOM COWLING

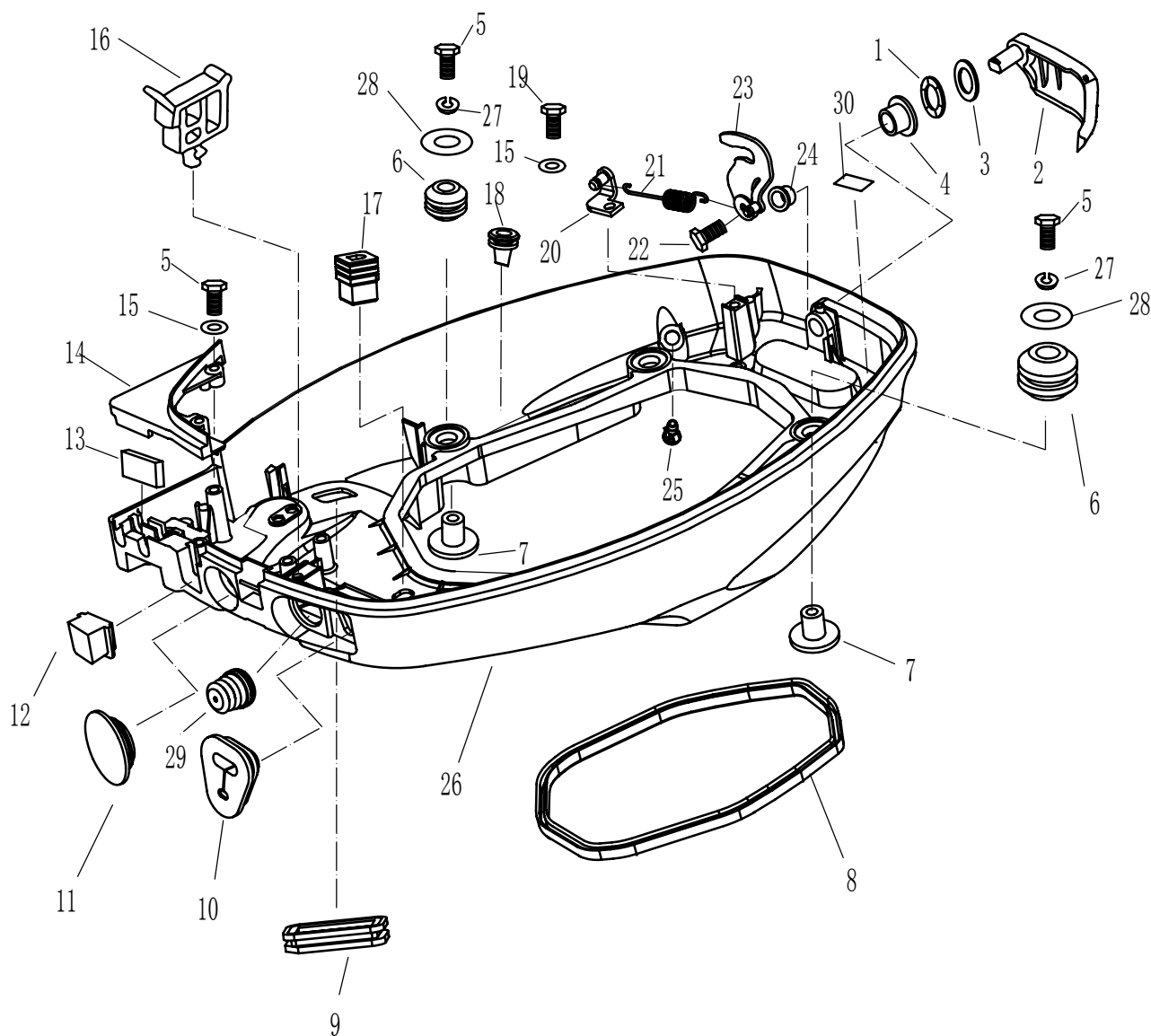

零部件名称:

控制系统

PARTS NAME:

CONTROL SYSTEM

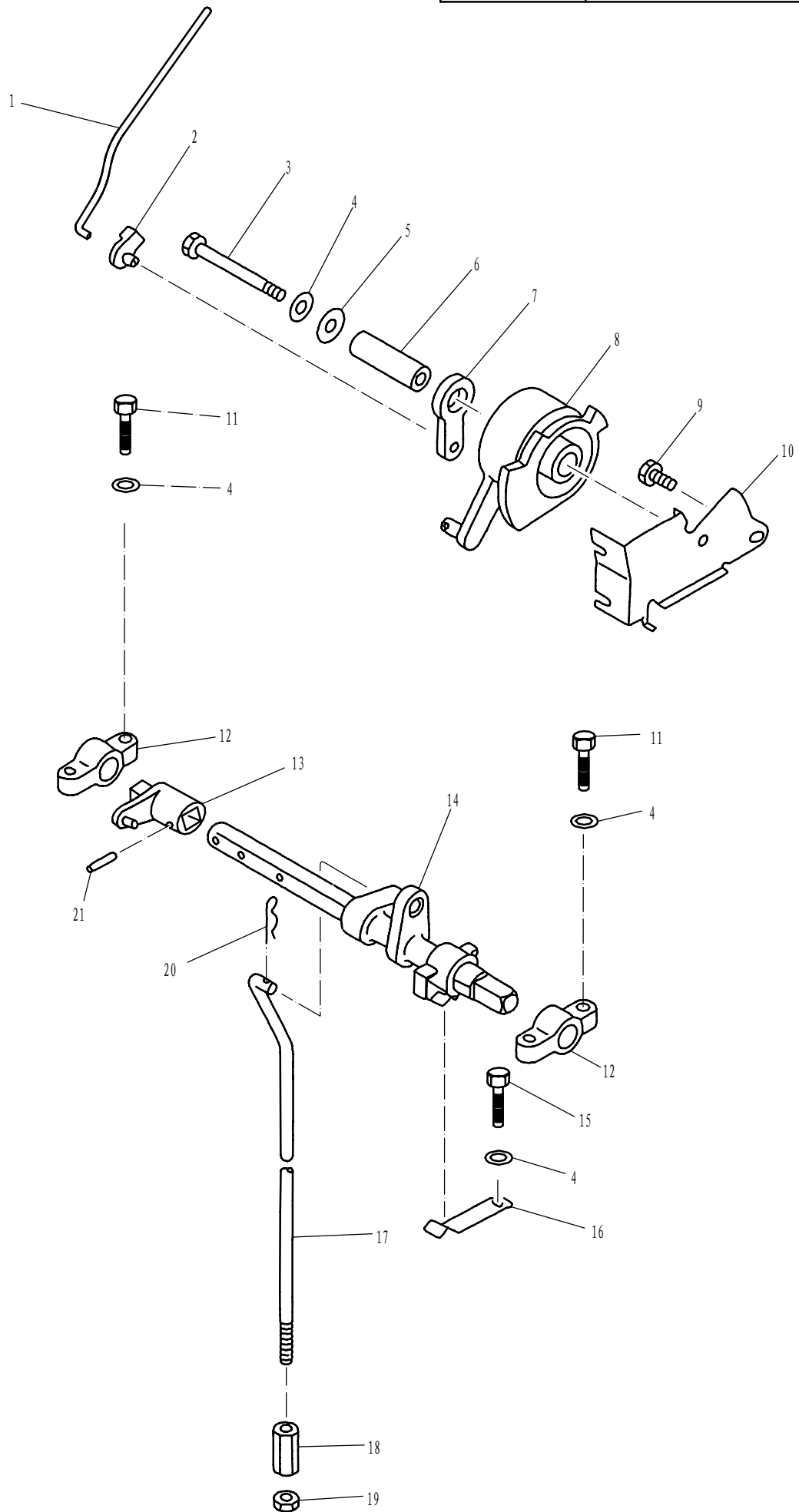

零部件名称:

水下装置壳体 & 驱动系统 1

PARTS NAME:

LOWER CASING & DRIVE 1

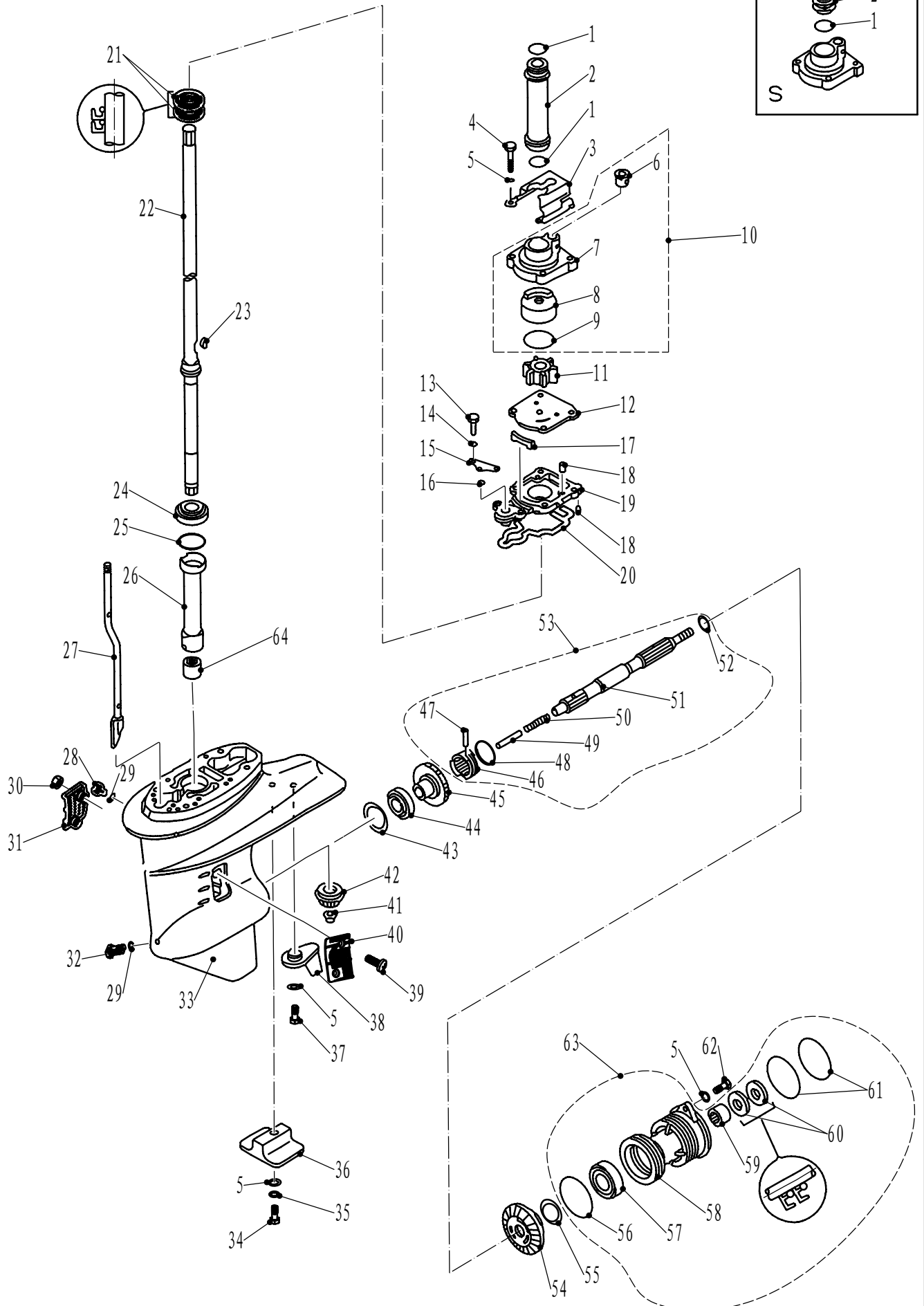

零部件名称:

水下装置壳体 & 驱动系统 1

PARTS NAME:

LOWER CASING & DRIVE 1

SN. 参照号码	PART NO. 零件编号	DESCRIPTION 零件名称 (中文)	DESCRIPTION 零件名称 (英文)	QTY 数量				REMARKS 备注
1	GB/T3452.1-25.8x2.65	O形圈25.8×2.65	O-RING 25.8x2.65	2				
2	F25-04000017	驱动轴尼龙套	TUBE , WATER	1				L
	F25-04000017S	驱动轴尼龙套	TUBE , WATER	1				S
3	F25-040000016	泵壳异形固定板	FIXED PLATE, WATER PUMP	1				
4	GB/T5782-M6x40	六角螺栓M6×40	BOLT M6x40	4				
5	GB/T97.1-6	平垫圈6	WASHER 6	8				
6	F25-04050004	水管密封圈	DAMPER , WATER PIPE	1				
7	F25-04050001	水泵壳体	SHELL , WATER PUMP	1				
8	F25-04050002	水泵内壳	SHELL , INNER	1				
9	F25-04050003	水泵壳体O形密封圈	O-RING	1				
10	F25-04050000	水泵壳体组件	SHELL ASSY, WATER PUMP	1				
11	F25-04040000	水泵叶轮组件	IMPELLER ASSY	1				
12	F25-04000014	外档板	OUTER PLATE	1				
13	GB/T5783-M6x25	六角螺栓M6×25	BOLT M6x25	2				
14	GB/T97.1-6	平垫圈6	WASHER 6	2				
15	F25-04000012	O形圈档板	PLATE , O-RING	1				
16	F15-06020004	O形密封圈	O-RING	1				
17	F25-04000013	水封	WATER SEAL	1				
18	F25-04000007	定位销Φ4x10	PIN, DOWEL	3				
19	F25-04000008	驱动轴座	BASE , DRIVE SHAFT	1				
20	F25-04000009	异形密封圈	SEAL	1				
21	F25-04010003	驱动轴油封22x36x6	OIL SEAL , DRIVE SHAFT	2				
22	F25-04010000	驱动轴组件	DRIVE SHAFT ASSY	1				L
	F25-04010000S	驱动轴组件	DRIVE SHAFT ASSY	1				S
23	F25-04000015	半圆键	SEMICIRCULAR KEY	1				
24	HR32004XJ	驱动轴圆锥滚子轴承	HOUSING, BEARING	1				
25	F25-04000003-1	驱动轴填隙片(t: 0.7毫米)	SHIM(t: 0.7mm)					
	F25-04000003-2	驱动轴填隙片(t: 1.0毫米)	SHIM(t: 1.0mm)					
	F25-04000003-3	驱动轴填隙片(t: 1.1毫米)	SHIM(t: 1.1mm)					
	F25-04000003-4	驱动轴填隙片(t: 1.2毫米)	SHIM(t: 1.2mm)					
	F25-04000003-5	驱动轴填隙片(t: 1.3毫米)	SHIM(t: 1.3mm)					
	F25-04000003-6	驱动轴填隙片(t: 1.4毫米)	SHIM(t: 1.4mm)					
	F25-04000003-7	驱动轴填隙片(t: 1.5毫米)	SHIM(t: 1.5mm)					
	F25-04000003-8	驱动轴填隙片(t: 1.6毫米)	SHIM(t: 1.6mm)					
26	F25-04000002	长尼龙套管	BUSHING , NYLON	1				
27	F25-04030000	变档凸轮组件	CAM ASSY, SHIFT ROD	1				L
	F25-04030000S	变档凸轮组件	CAM ASSY, SHIFT ROD	1				S
28	F4-03000023	注油孔螺塞	PLUG, HOLE OIL	1				
29	F4-03000024	注油孔螺塞垫圈	GASKET	2				
30	GB/T889.1-M5	I型非金属嵌件六角锁紧螺母M5	NUT, LOCKING M5	2				
31	F25-04000023	进水口B	WATER INLET "B"	1				
32	F25-04000031	放油螺塞	PLUG, DRAIN	1				
33	F25-04000001	水下装置壳体	LOWER CASING	1				

零部件名称:

电气

PARTS NAME:

ELECTRICAL

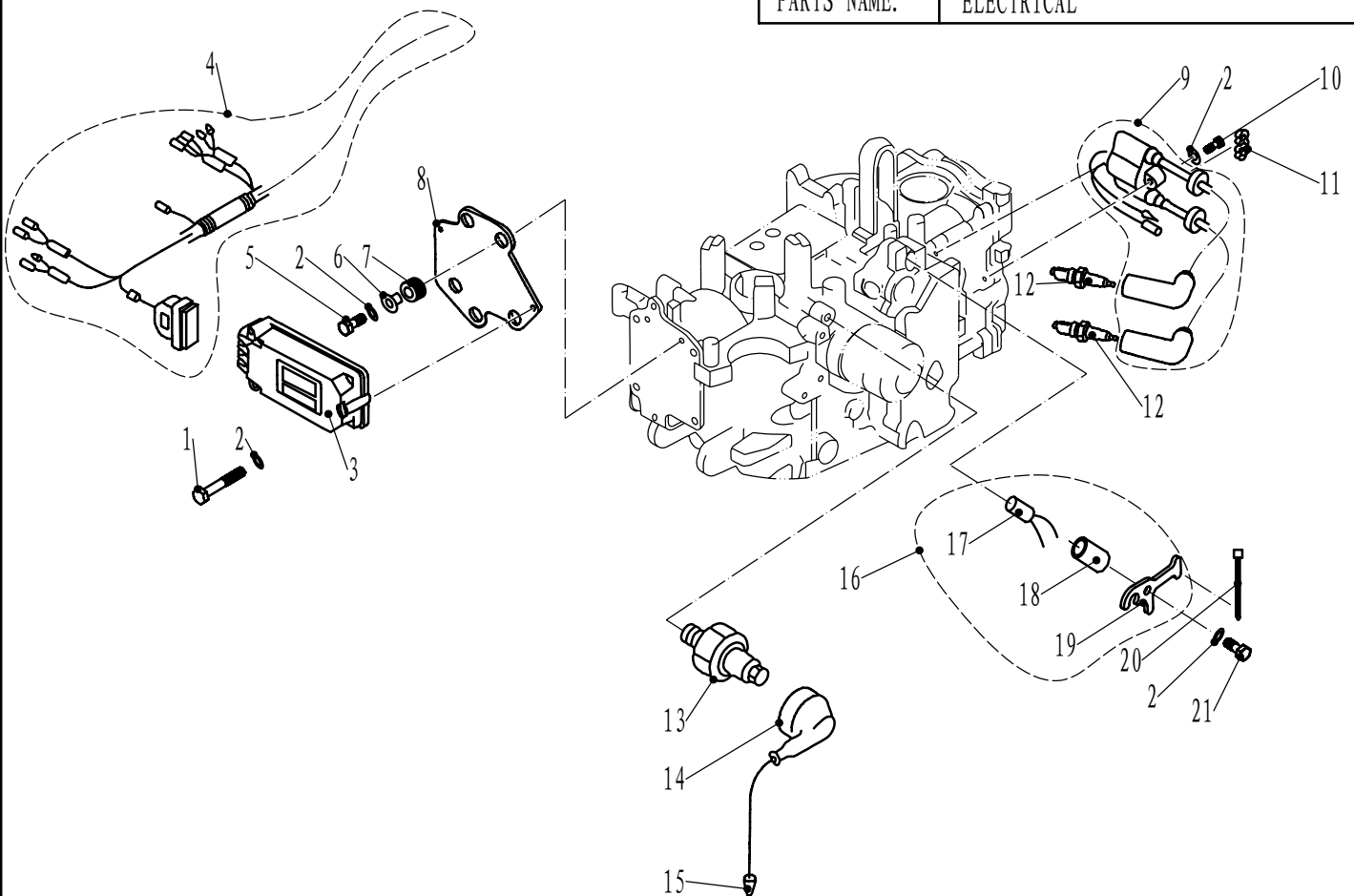

SN. 参照号码	PART NO. 零件编号	DESCRIPTION 零件名称(中文)	DESCRIPTION 零件名称(英文)	QTY 数量				REMARKS 备注
1	GB/T6563-M6x45	六角头自攻锁紧螺钉M6×45	SCREW , LOCKED M6x45	3				
2	GB/T97.1-6	平垫圈6	WASHER 6	8				
3	F25-05090001	点火模块组件	C. D. I. UNIT ASSY	1				
4	F25-05090002	点火线束组件	C. D. I. LINE ASSY	1				
5	GB/T5783-M6x25	六角螺栓M6×25	BOLT M6x25	3				
6	F25-05090005	点火模块减震圈衬管	BUSH , IGNITION	3				
7	F25-05090004	点火模块减震圈	BUSH , DAMPING	3				
8	F25-05090003	点火模块固定板	BRACKET , IGNITION UNIT	1				
9	F25-05120000	高压包组件	HIGH PRESSURE ASSY	1				
10	GB/T5783-M6x30	六角螺栓M6x30	BOLT M6x30	1				
11	F25-05000016	尼龙管夹	CLAMP , NYLON	1				
12	DPR6EA-9 NGK	火花塞	SPARKPLUG	2				
13	F15-07010103	机油压力传感器	OIL PRESSURE SENSOR	1				
14	F15-07010101	绝缘护套	JACKET , INSULATION	1				
15	F15-07010102	导线组件	LEAD WIRE ASSY	1				
16	F25-05010200	温控器组件	TEMPERATURE CONTROLLER ASS'Y	1				
17	F25-05010201	温控器	TEMPERATURE CONTROLLER	1				
18	F25-05010202	温控器护套	BUSH , TEMPERATURE CONTROLLER	1				
19	F25-05010203	温控器固定板	PLATE , TEMPERATURE CONTROLLER	1				
20	HT-25×60	尼龙扎带	BAND NYLON	1				
21	GB/T5783-M6x12	六角螺栓 M6×12	BOLT M6×12	1				

零部件名称:

进气系统

PARTS NAME:

INTAKE

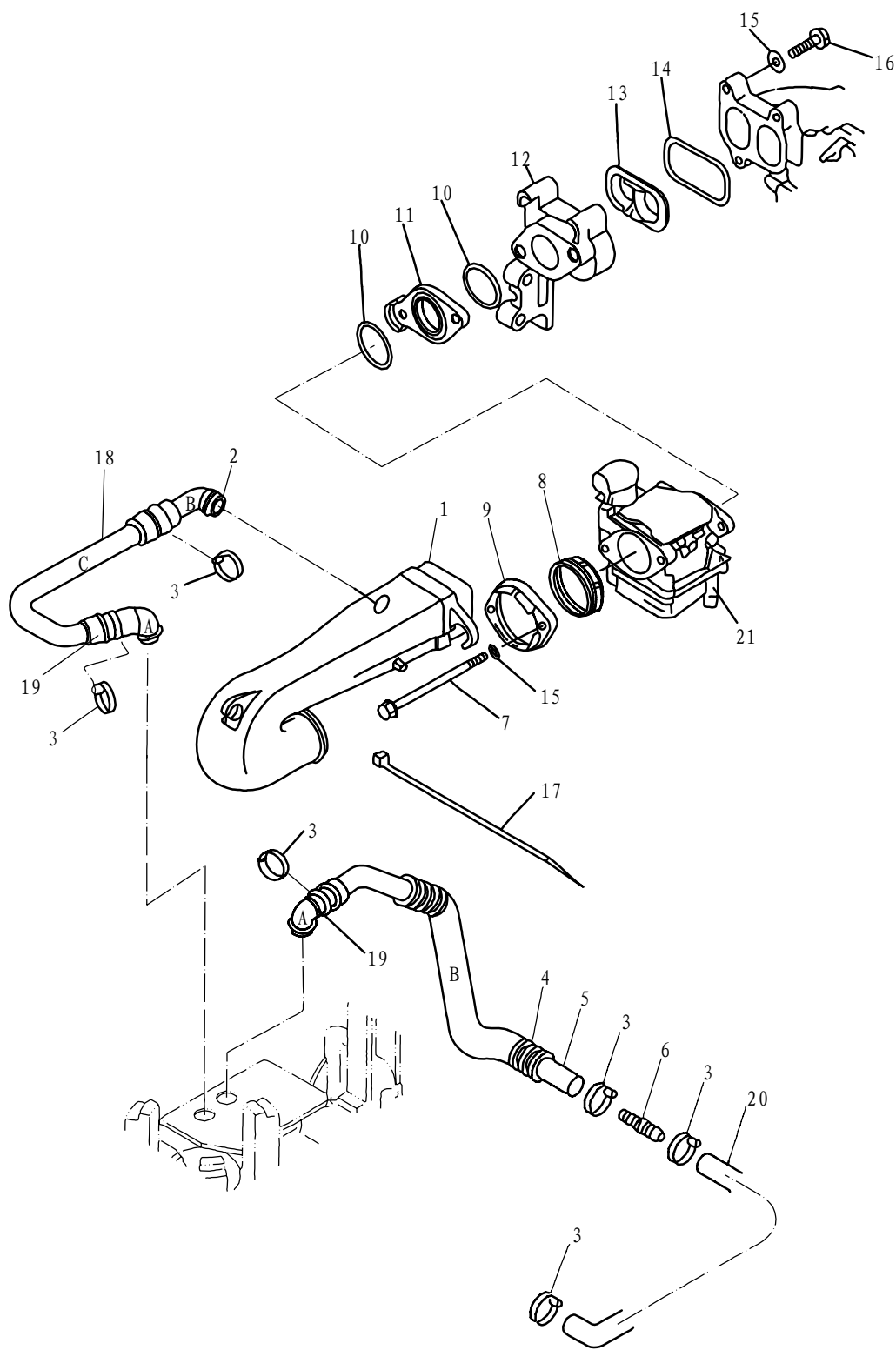

零部件名称:

气缸和曲轴箱

PARTS NAME:

CYLINDER&CRANKCASE

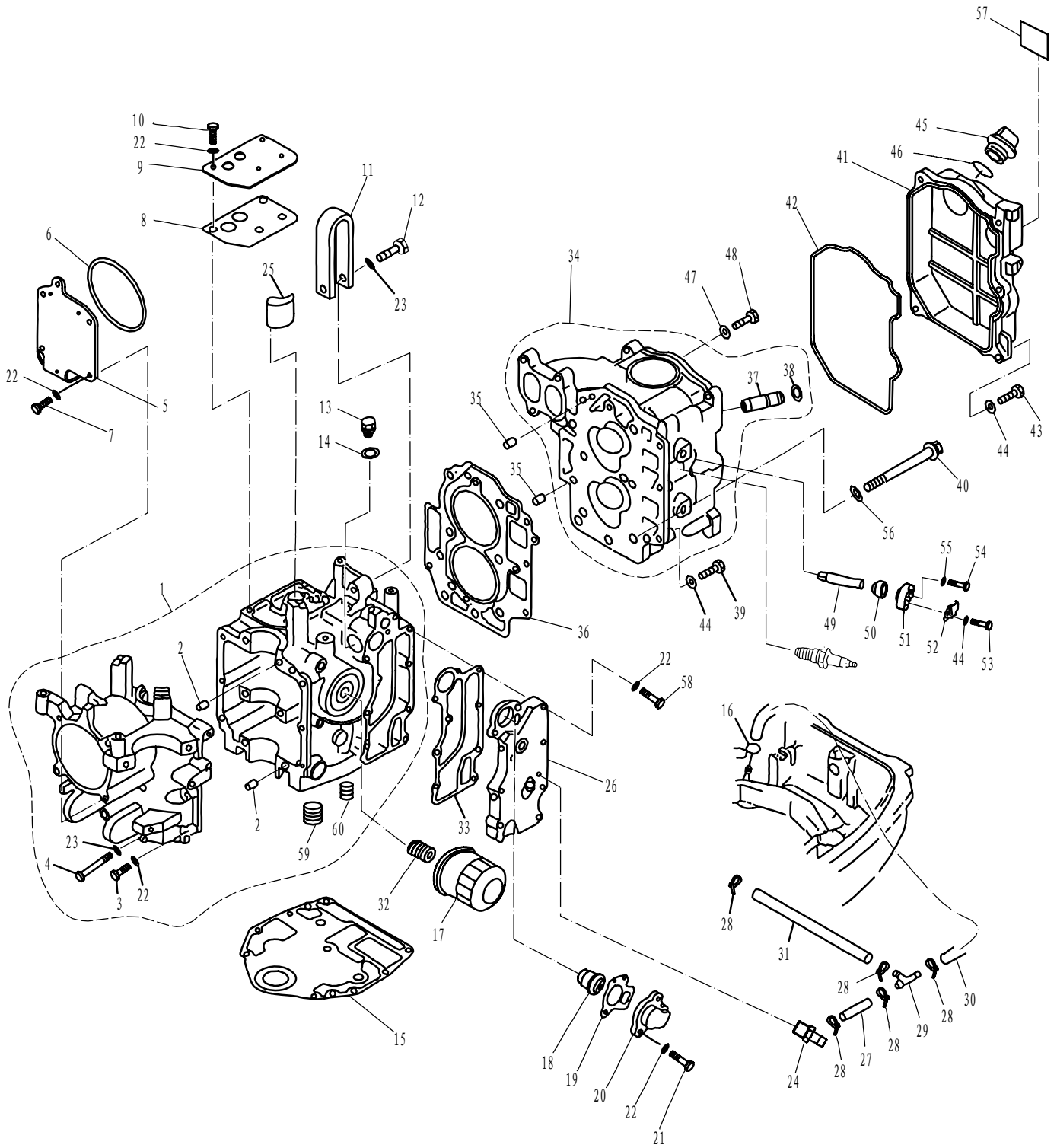

零部件名称:

气缸和曲轴箱

PARTS NAME:

CYLINDER&CRANKCASE

SN. 参照号码	PART NO. 零件编号	DESCRIPTION 零件名称 (中文)	DESCRIPTION 零件名称 (英文)	QTY 数量				REMARKS 备注
1	F25-05010000	机体机座组件	CRANKCASE ASSY	1				
2	F25-00000014	定位销 ϕ 8x12	PIN, DOWEL	2				
3	GB/T5782-M6x35	六角螺栓M6X35	BOLT, HEXAGON M6x35	6				
4	GB/T5782-M8x80	六角螺栓M8X80	BOLT, HEXAGON M8x80	6				
5	F25-05000007	平衡缸盖板	CRANKCASE	1				
6	GB/T3452.1-97.5x1.8	O型圈 97.5x1.8	SEAL 97.5x1.8	1				
7	GB/T5783-M6x20	六角螺栓M6X20	BOLT, HEXAGON M6x20	4				
8	F25-05010108	呼吸器橡胶密封垫	GASKET, BREATHER COVER	1				
9	F25-05010109	呼吸器盖板	COVER, BREATHER	1				
10	GB/T5783-M6x20	六角螺栓M6X20	BOLT, HEXAGON M6x20	4				
11	F25-05010106	发动机悬挂钩	HANGER, ENGINE	1				
12	GB/T5782-M8x35	六角螺栓 M8X35	BOLT HEXAGON M8x35	1				
13	F15-04000002	放油螺栓	BOLT, OIL DRAIN	1				
14	F15-04000003	放油螺栓垫片	WASHER	1				
15	F25-00000013	发动机密封垫	GASKET, ENGINE	1				
16	F4-04000030	油管夹簧B	SPRING, FUEL PIPE"B"	1				
17	F15-07010023	机油滤清器	OIL CLEANER	1				
18	F4-04000036	节温器	THERMOSTAT	1				
19	F15-07010022	节温器垫	GASKET, THERMOSTAT	1				
20	F15-07010021	节温器盖板	COVER, THERMOSTAT	1				
21	GB/T5783-M6x25	六角螺栓M6X25	BOLT M6x25	2				
22	GB/T97.1-6	平垫圈6	WASHER 6	17				
23	GB/T97.1-8	平垫圈8	WASHER 8	7				
24	F25-05010113	出水嘴接头	NIPPLE, HOSE	1				
25	F25-05010107	呼吸器滤网	CLEANER	1				
26	F25-05010112	排气盖板	OUTER COVER, EXHAUST	1				
27	F25-03000008	水管A	HOSE	1				
28	HT-2.5x60	尼龙扎带	CLAMP	5				
29	F15-05000011	三通	THREE-WAY PIPE	1				
30	F25-03000011	水管C	HOSE	1				
31	F25-03000009	水管B	HOSE	1				
32	F15-07010003	机滤螺柱	BOLT, UNION	1				
33	F25-05010111	排气盖板密封垫	GASKET, EXHAUST OUTER COVER	1				
34	F25-05050100	气缸头组件	CYLINDER HEAD ASSY	1				
35	F25-00000014	定位销 ϕ 8x12	PIN, DOWEL	2				
36	F25-05040000	气缸垫组件	GASKET, CYLINDER HEAD	1				
37	F25-05050104	气门导管	VALVE GUIDE BUSH	4				
38	F15-07040105	气门导管卡簧	CIRCLIP, GUIDE BUSH	4				
39	GB/T5783-M6x25	六角头螺栓M6X25	BOLT, HEXAGON M6x25	3				
40	F25-05000002	六角头凸缘螺栓M9X95	BOLT, FLANGE	6				
41	F25-05000005	气缸头罩	COVER, CYLINDER HEAD	1				
42	F25-05000004	气缸头罩密封圈	SEAL, CYLINDER COVER	1				
43	GB/T5783-M6x20	六角头螺栓M6X20	BOLT, HEXAGON M6x20	5				

零部件名称:

曲轴和活塞

PARTS NAME:

CRANKSHAFT&PISTON

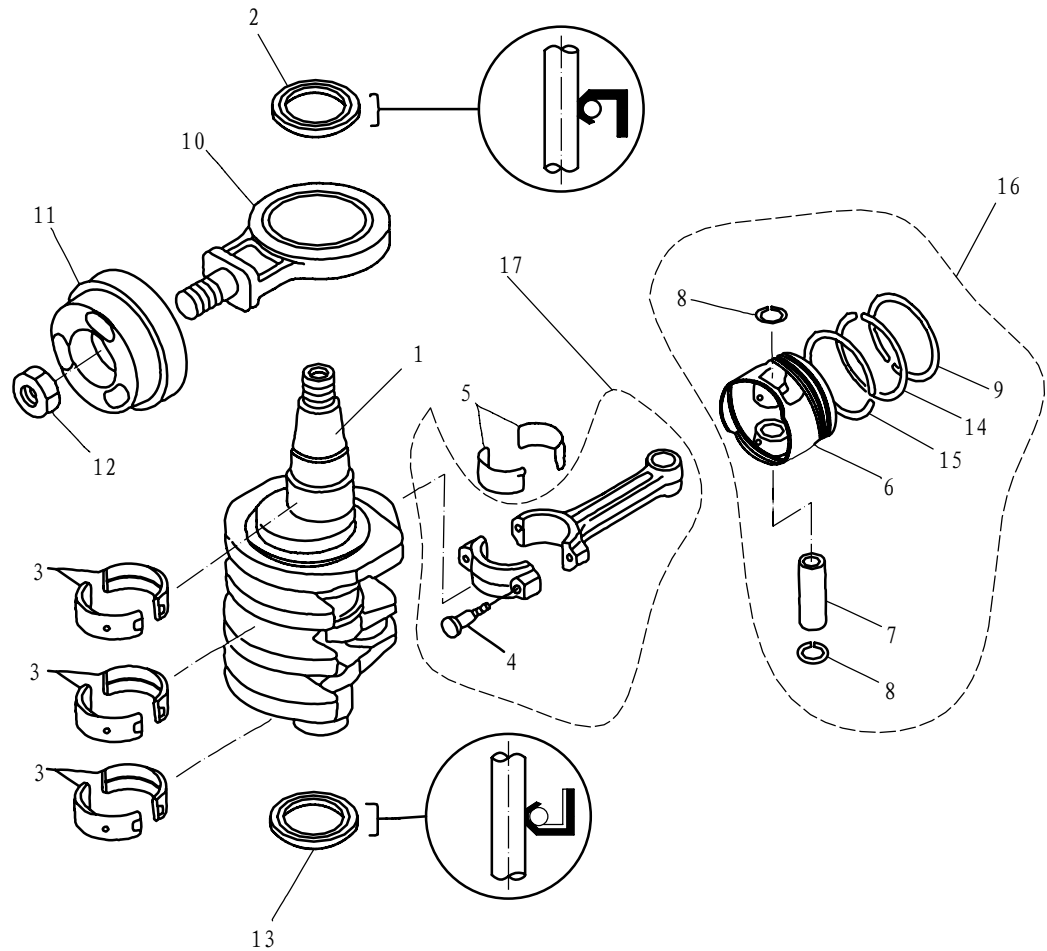

SN. 参照号码	PART NO. 零件编号	DESCRIPTION 零件名称(中文)	DESCRIPTION 零件名称(英文)	QTY 数量				REMARKS 备注
1	F25-05020001	曲轴	CRANK SHAFT	1				
2	F25-05020002	曲轴油封 B	OIL SEAL B	1				
3	F25-05010302-1	曲轴轴瓦	MAIN BEARING	6				UR: BROWN
	F25-05010302-2	曲轴轴瓦	MAIN BEARING	6				
4	F25-05020204	连杆螺栓	BOLT, CONNECTING ROD	2				
5	F25-05020203-1	连杆轴瓦	PLANE BEARING, CONNECTING ROD	2				UR: BLACK
	F25-05020203-2	连杆轴瓦	PLANE BEARING, CONNECTING ROD	2				
6	F25-05020101	活塞	PISTON	2				
7	F25-05020105	活塞销	PIN, PISTON	2				
8	F25-05020106	活塞销挡圈	CIRCLIP	4				
9	F25-05020102	活塞环 I	PISTON RING I	2				
10	F25-05020310	平衡缸连杆组件	CON-ROD ASSY, BALANCE	1				
11	F25-05020301	平衡缸活塞	PISTON, BALANCE	1				
12	F25-05000026	飞轮螺母	NUT	1				
13	F25-05020002	曲轴油封 A	OIL SEAL A	1				
14	F25-05020103	活塞环 II	PISTON RING II	2				
15	F25-05020104	组合油环	COMBINA OIL RING	2				
16	F25-05020100	活塞组件	PISTON ASSY	2				
17	F25-05020200	连杆组件	ROD, CONNECTING	2				

零部件名称:

燃油系统

PARTS NAME:

FUEL 1

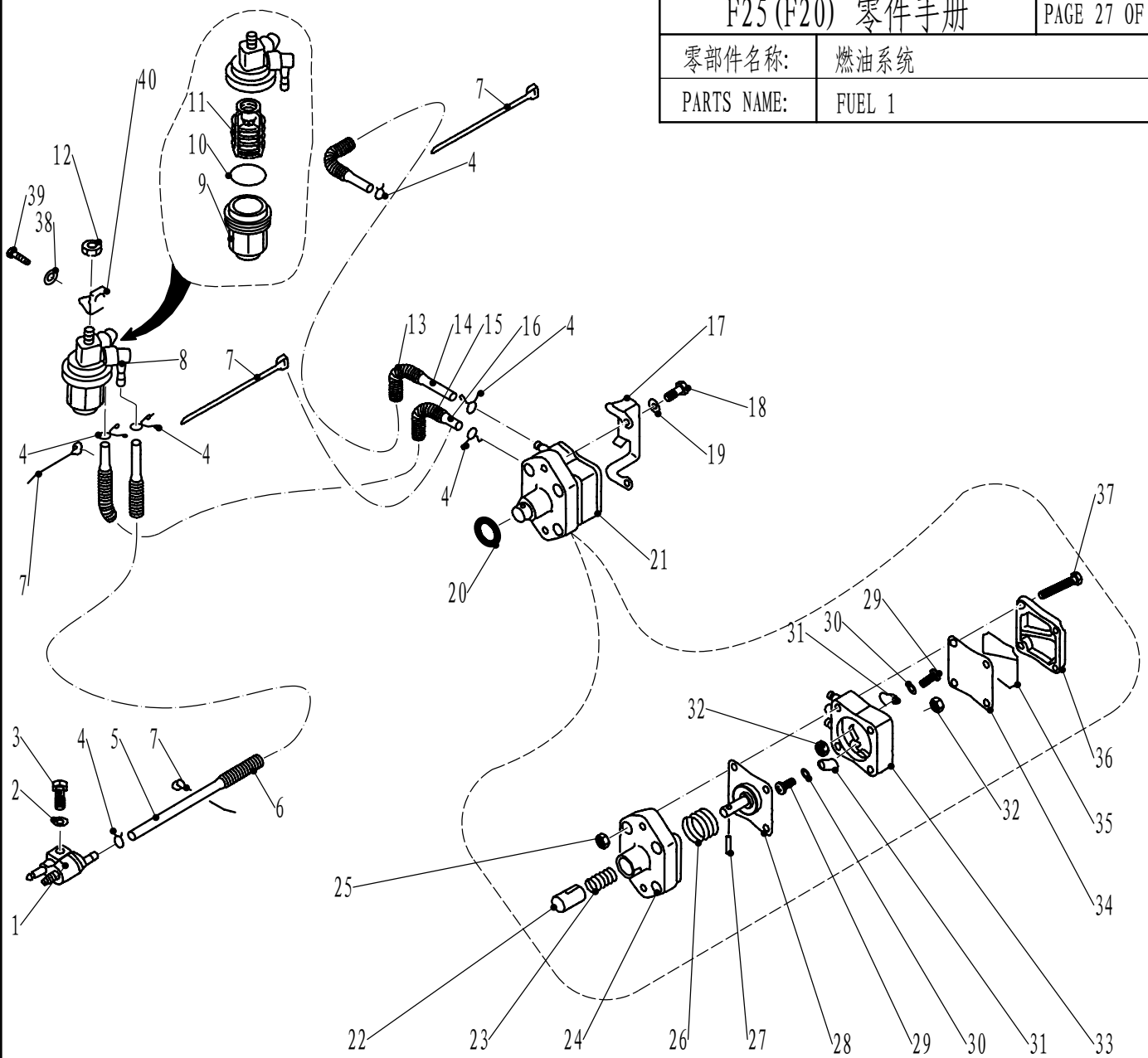

SN. 参照号码	PART NO. 零件编号	DESCRIPTION 零件名称(中文)	DESCRIPTION 零件名称(英文)	QTY 数量				REMARKS 备注
1	F4-05000200	燃油接头组件	FUEL PIPE TIE-IN ASSY	1				
2	GB/T97.1-6	平垫圈6	WASHER 6	1				
3	GB/T5783-M6x25	六角螺栓M6×25	BOLT M6x25	1				
4	F4-04000030	油管夹簧B	SPRING, FUEL PIPE "B"	5				
5	F25-03000012	燃油管A	PIPE, FUEL "A"	1				Φ10xΦ5x550
6	F25-03000004	波纹管护套	PIPE, WAVE	1				Φ12x120
7	HT-2.5×60	尼龙扎带	CLAMP	6				
8	F15-07080000	滤油杯组件	FILTER ASSY	1				
9	F15-07080002	滤杯	CUP, FILTER	1				
10	GB/T3452.1-32.5x1.8	滤杯密封圈φ32.5×1.8	WASHER, CUP FILTER φ32.5x1.8	1				
11	F15-07080001	滤网架	ELEMENT, FILTER	1				
12	GB/T6170-M8	六角螺母M8	NUT M8	1				
13	F25-05000029	波纹管	PIPE, WAVE	1				Φ12x300
14	F25-05000012	燃油管	PIPE, FUEL	1				Φ10xΦ5x350
15	F25-05000033	波纹管	PIPE, WAVE	1				Φ12x120

零部件名称: 起动机

PARTS NAME: STARTER

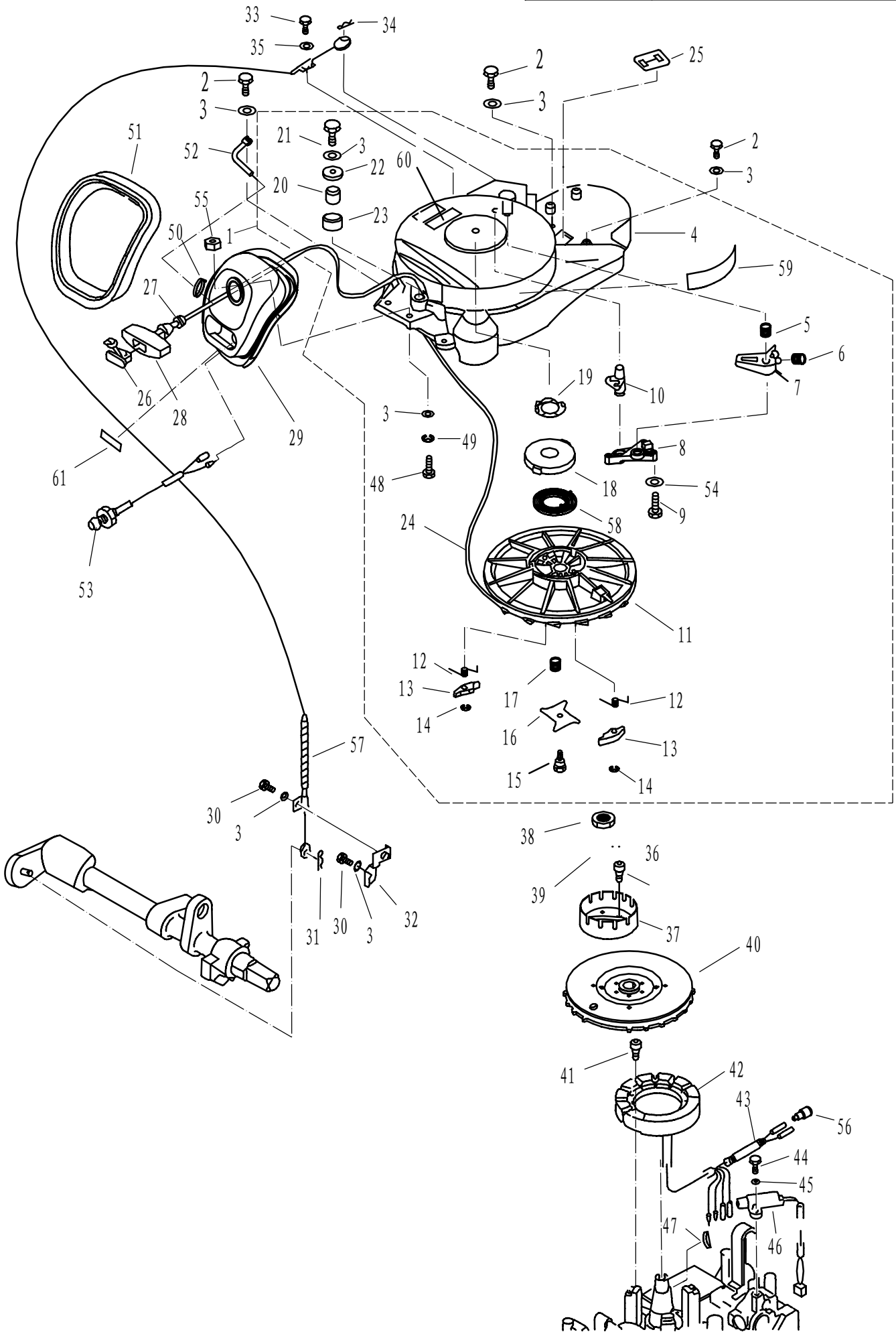

零部件名称:

起动器

PARTS NAME:

STARTER

SN. 参照号码	PART NO. 零件编号	DESCRIPTION 零件名称(中文)	DESCRIPTION 零件名称(英文)	QTY 数量					REMARKS 备注
1	F25-05160000	起动器组件	STARTER ASSY	1					
2	GB/T5783-M6x25	六角螺栓M6x25	BOLT M6x25	4					
3	GB/T97.1-6	平垫圈6	WASHER, PLATE 6	9					
4	F25-05160100	起动器外壳组件	CASE, STARTER	1					
5	F25-05160003	制动器扭簧	SPRING, ARRESTER	1					
6	F25-05160005	卡瓣弹簧	SPRING, TENSION	1					
7	F25-05160001	制动器	ARRESTER	1					
8	F25-05160006	制动器固定盖板	ARRESTER, CHANGELESS	1					
9	GB/T5285-FST4.8x26	六角头自攻螺钉ST4.8x26 (F型)	SCREW, TAPPING ST4.8x26	3					
10	F25-05160004	制动器卡瓣	PAWL, DRIVE	1					
11	F25-05160301	起动轮	WHEEL, START-UP	1					
12	F25-05160304	起动卡瓣扭簧	PAWL, DRIVE SPRING	2					
13	F25-05160305	起动卡瓣	PAWL, DRIVE	2					
14	GB/T896-6	开口档圈6	CIRCLIP 6	2					
15	F25-05160018	压板螺钉	PLATE, DRIVE BOLT	1					
16	F25-05160017	起动压板	PLATE, DRIVE	1					
17	F25-05160016	起动压板弹簧	SPRING, DRIVE PLATE	1					
18	F25-05160014	涡形弹簧座	SEAT, SPRING	1					
19	F25-05160013	涡形弹簧座弹性垫片	CUSHION, SPRING, SEAT	1					
20	F25-05160009	起动绳滑轮轴	AXES, PUIIEY	1					
21	GB/T5783-M6x30	六角螺栓M6x30	BOLT M6x30	1					
22	GB/T5287-6	特大垫圈6	WASHER, OUTSIZE 6	1					
23	F25-05160008	起动绳滑轮	PUIIEY, STARTLING	1					
24	F25-05160019	锦纶编织线φ5x1.68米	START LING	1					
25	F25-05160012	橡胶护盖	JACKET, RUBBER	1					
26	F4-04130102	起动手柄盖	COVER	1					
27	F25-05160021	手柄减震圈	DAMPING	1					
28	F25-05160501	起动手柄	HANDLE, STARTER	1					
29	F25-05160401	起动架	FRAME, STARTER	1					
30	GB/T5783-M6x10	六角螺栓M6x10	BOLT M6x10	2					
31	F15-00000012	夹簧φ1.8	SPRING	1					
32	F25-05000028	制动器固定板	STAY, CABLE COMP	1					
33	GB/T5783-M5x12	六角螺栓M5x12	BOLT M5x12	1					
34	F25-05160002	夹簧φ1	SPRING	1					
35	GB/T96-5	大垫圈5	BIG WASHER 5	1					
36	GB/T70.1-M8x12	内六角螺栓M8x12	BOLT M8x12	3					
37	F25-05000027	起动轴套	JUMP START, AXES	1					
38	F25-05000026	飞轮螺母	NUT, FLYWHEEL	1					
39	F25-05000025	飞轮螺母垫圈	WASHER, FLYWHEEL NUT	1					
40	F25-05150000	飞轮组件	FLYWHEEL SAAY	1					
41	GB/T70.1-M5x25	内六角螺栓M5x25	BOLT M5x25	3					
42	F25-05140000	磁电机线圈组件	STATOR ASSY	1					
43	F25-05000034	波纹管Φ8x90	RIPPLE JACKET	1					

零部件名称:

附录1(修理件)

PARTS NAME:

APPENDIX 1 (REPAIR KIT)

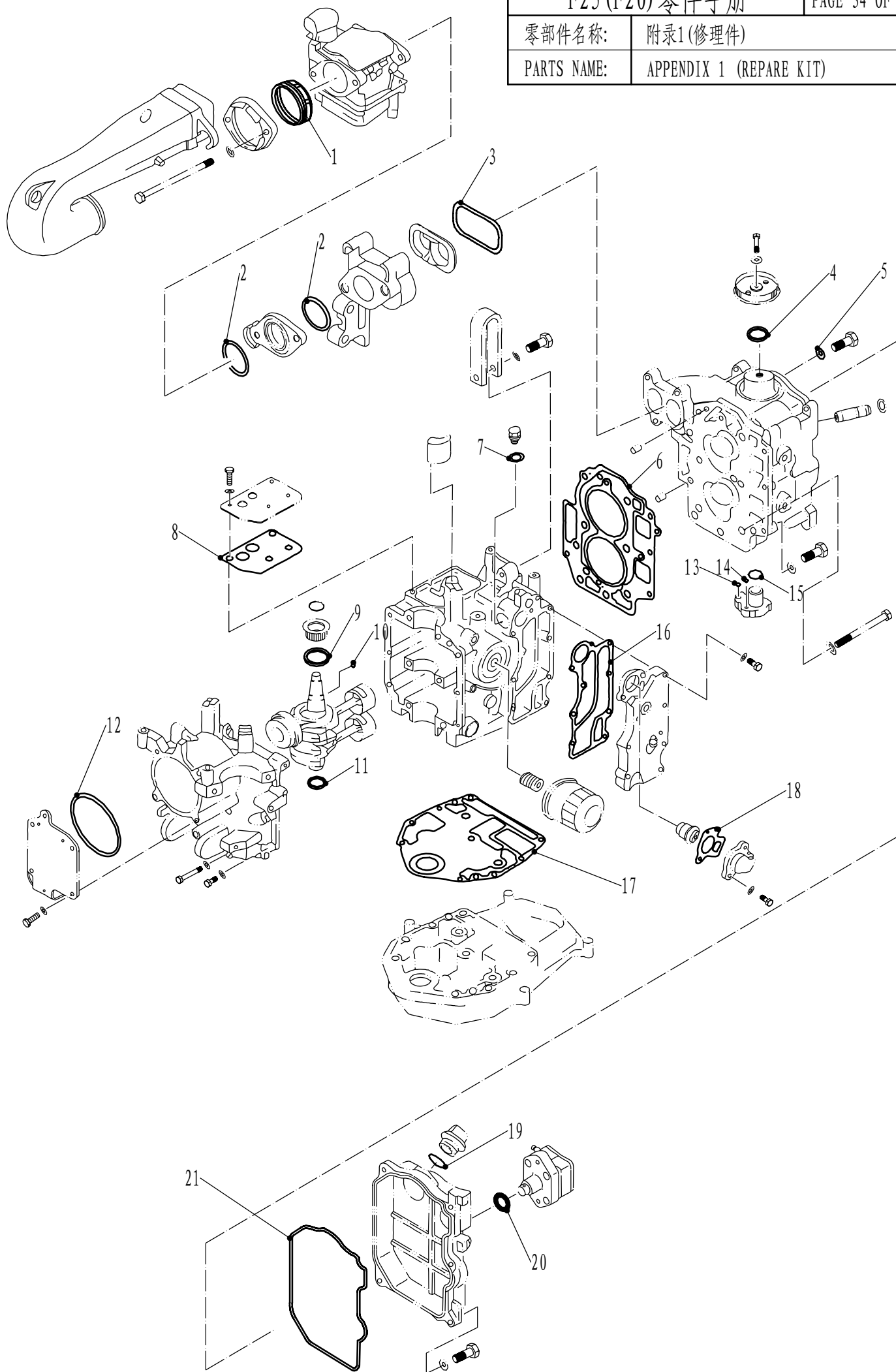

零部件名称:

附录2 (修理件)

PARTS NAME:

APPENDIX 2 (REPAIR KIT)

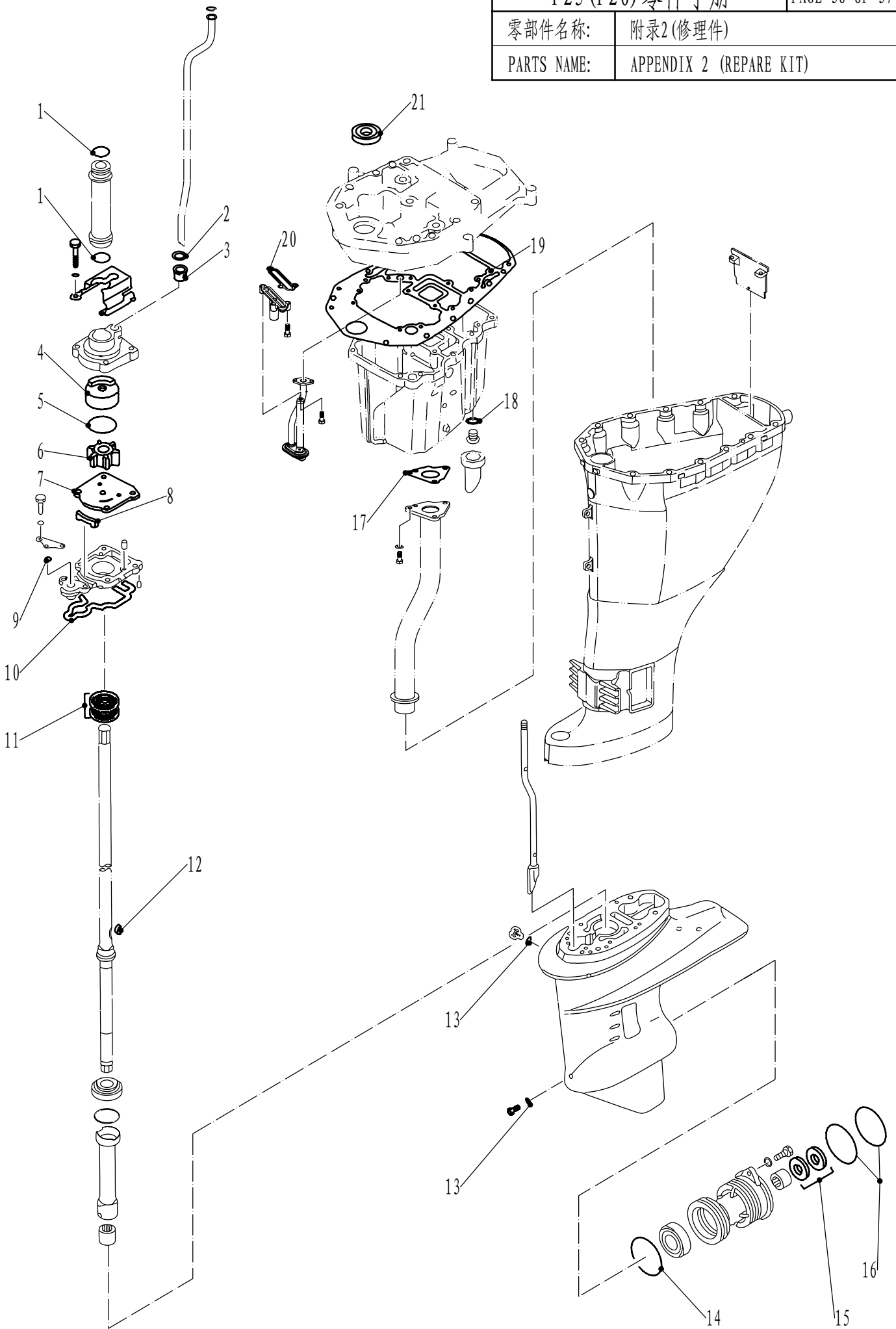

零件手册

零部件名称: 化油器总成

PARTS NAME: CARBURETOR ASSY

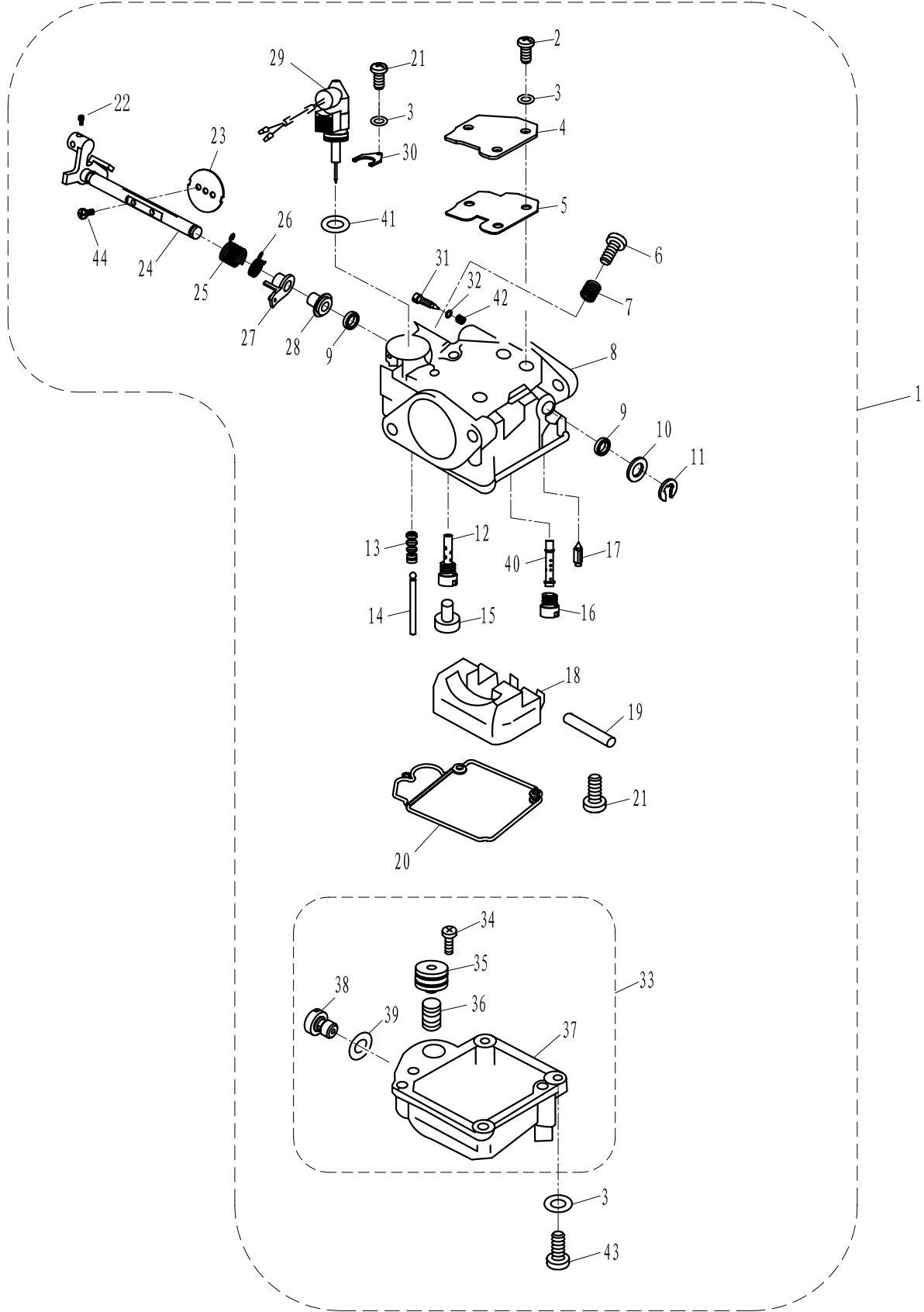

SN. 参照号码	PART NO. 零件编号	DESCRIPTION 零件名称(中文)	DESCRIPTION 零件名称(英文)	QTY 数量			REMARKS 备注
1	F25-05070000	化油器总成	CARBURETOR ASSY	1			
2	GB/T818-M4x12	十字槽盘头螺钉M4x12	BOLT M4x12	3			

零件手册

零部件名称:

化油器总成

PARTS NAME:

CARBURETOR ASSY

SN. 参照号码	PART NO. 零件编号	DESCRIPTION 零件名称(中文)	DESCRIPTION 零件名称(英文)	QTY 数量				REMARKS 备注
3	GB/T93-4	弹性垫圈4	WASHER, SPRING	8				
4	F25-05070003	面板	PLATE	1				
5	F25-05070002	衬垫	GASKET	1				
6	F25-05070010	油门止动螺钉	BOLT	1				
7	F25-05070011	油门止动螺钉弹簧	SPRING, THORTTEL	1				
8	F25-05070001	化油器本体	CARBURETOR	1				
9	F25-05070005	橡胶密封圈	SEAL	2				
10	F25-05070012	摆杆垫圈	GASKET	1				
11	GB/T896-4	开口挡圈4	CIRCLIP	1				
12	F25-05070022	怠速量孔	NOZZLE, MAIN	1				
13	F25-05070025	加浓阀波纹橡胶护套	WAVE JACKET, VALVE	1				
14	F25-05070024	加浓阀顶杆	WAVE MANDRIL, VALVE	1				
15	F25-05070023	胶帽	RUBBER CAP	1				
16	F25-05070021	主量孔	MAIN, JET	1				
17	F25-05070017	针阀	VALVE, NEEDLE	1				
18	F25-05070018	浮子	FLOAT	1				
19	F25-05070019	浮子销	PIN, FLOAT	1				
20	F25-05070026	油杯密封垫	GASKET, FLOAT CHAMBER	1				
21	GB/T818-M4x8	十字槽盘头螺钉M4x8	BOLT M4x8	2				
22	GB/T818-M4x6	十字槽盘头螺钉M4x6	BOLT M4x6	1				
23	F25-05070006	油门挡板	APRON, ACCELERATOR	1				
24	F25-05070100	油门摆杆组件	SWING LINK, ACCELERATOR	1				
25	F25-05070004	油门摆杆扭簧	WRING SPRING	1				
26	F25-05070009	加浓阀摆杆扭簧	TWIST SPRING, SWING LINK	1				
27	F25-05070008	加浓阀摆杆	SWING LINK, VALVE	1				
28	F25-05070007	油门摆杆衬套	BUSH, SWING LINK	1				
29	F25-05070200	电子加浓阀组件	VALVE ASSY, ELECTRICAL	1				
30	F25-05070016	电子加浓阀固定板	PLATE, VALVE	1				
31	F25-05070013	怠速螺钉	SCREW, AIR ADJUSTING	1				
38	F25-05070014	O型圈	SEAL	1				
39	F25-05070300	油杯组件	BODY, FLOAT CHAMBER	1				
34	GB/T818-M2x3	十字槽盘头螺钉M2x3	BOLT M2x3	1				
35	F25-05070302	加浓阀柱塞	PLUG, VALVE	1				
36	F25-05070301	加浓阀弹簧	SPRING, VALVE	1				
37	F25-05070305	油杯	CUP, BODY	1				
38	F25-05070303	放油螺钉	SCREW, DRAIN	1				
39	F25-05070304	螺钉垫片	GASKET	1				
40	F25-05070020	主喷嘴	MAIN, NOZZLE	1				
41	F25-05070201	电子加浓阀O型圈	O-RING	1				
42	F25-05070015	怠速螺钉弹簧	SPRING, PILOT ADJUSTING	1				
43	GB/T818-M4x14	十字槽盘头螺钉M4x14	BOLT M4x14	4				
44	GB/T818-M3x6	十字槽盘头螺钉M3x6	BOLT M3x6	2				