

零件目录

PARTS CATALOGUE

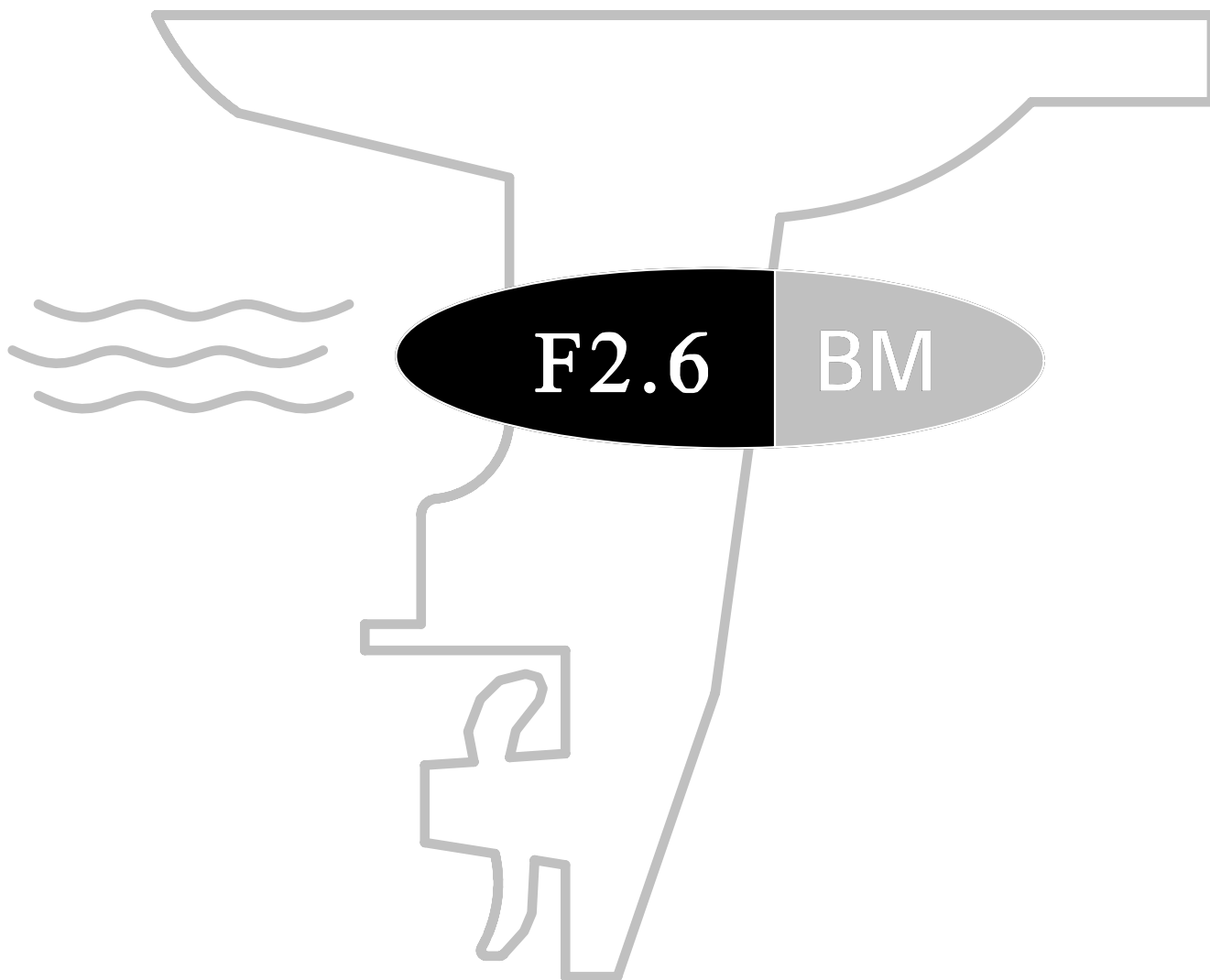

苏州百胜动力机器有限公司

SUZHOU PARSUN POWER MACHINE CO., LTD

目录

CONTENTS

控制系统	1~2
CONTROL	1~2
托架	3~4
BRACKET	3~4
操舵系统	5~6
STEERING	5~6
水上装置壳体	7~8
UPPER CASING	7~8
水下装置壳体和驱动系统1	9~10
LOWER CASING & DRIVE 1	9~10
水下装置壳体和驱动系统 2	11~12
LOWER CASING & DRIVE 2	11~12
点火系统	13
IGNITION ASS'Y	13
气缸和曲轴箱1	14~15
CYLINDER & CRANKCASE 1	14~15
曲轴和活塞	16
CRANKSHAFT & PISTON	16
凸轮轴和阀门	17
CAMSHAFT & VALVE	17
气缸和曲轴箱2	18~19
CYLINDER & CRANKCASE 2	18~19
燃油系统	20~21
FUEL	20~21
进气系统	22
INTAKE	22
起动机组件	23
STARTER	23
底罩	24
BOTTOM COWLING	24
顶罩	25
TOP COWLING	25
修理件1	26~27
REPAIR KIT 1	26~27
修理件2	28~29
REPAIR KIT 2	28~29

零部件名称: 控制系统

PARTS NAME: CONTROL

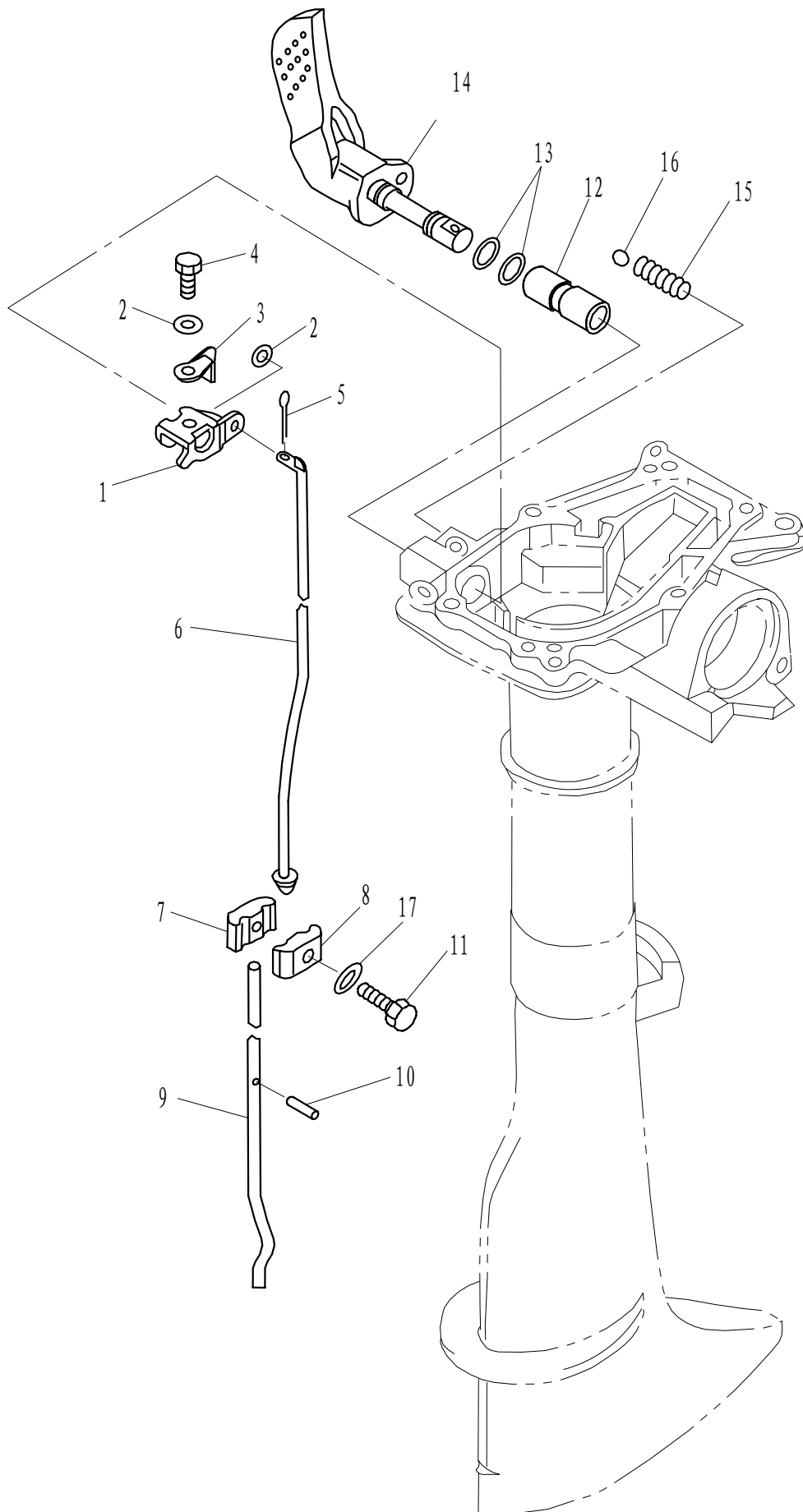

零部件名称:

托架

PARTS NAME:

BRACKET

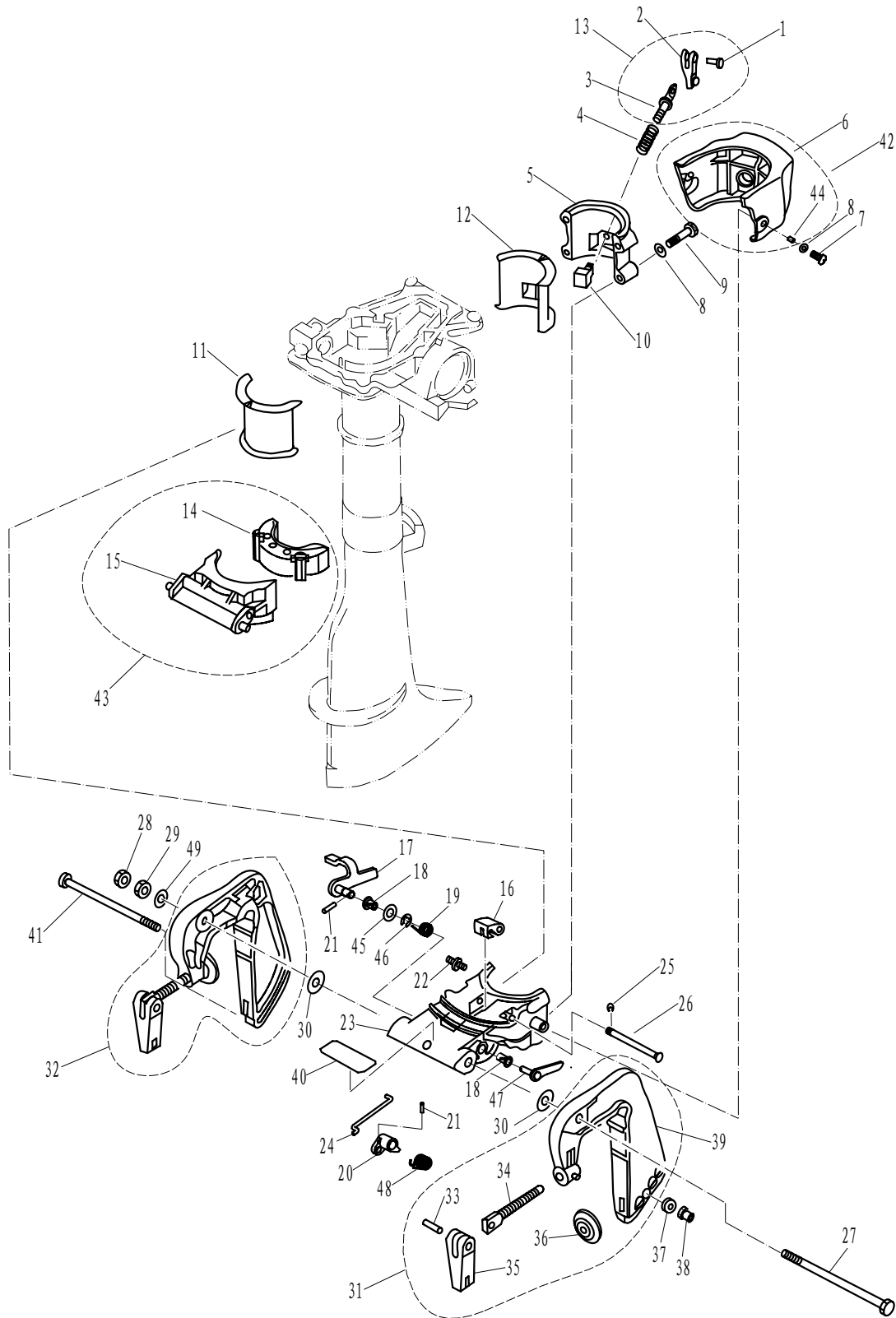

SN. 参照号码	PART NO. 零件编号	DESCRIPTION 零件名称(中文)	DESCRIPTION 零件名称(英文)	QTY 数量					REMARKS 备注
1	GB/T875-4x11	扁平头半空心铆钉 ϕ 4x11	RIVET ϕ 4x11	1					
2	F4-01060002	锁紧手柄	CLAMP HANDLE	1					
3	F2.6-01050101	锁紧手柄螺杆	LOCKED SCREW	1					
4	F2.6-01050002	压缩弹簧	SPRING	1					
5	F2.6-01050001	旋转支架盖	COVER, SWIVEL BRACKET	1					
6	F2.6-00000101	托架护盖	COVER, BRACKET	1					

零部件名称:

托架

PARTS NAME:

BRACKET

SN. 参照号码	PART NO. 零件编号	DESCRIPTION 零件名称(中文)	DESCRIPTION 零件名称(英文)	QTY 数量					REMARKS 备注
7	GB/T818-M6x16	十字槽盘头螺钉M6x16	SCREW, PAN HEAD M6x16	2					
8	GB/T97.1-6	平垫圈6	WASHER 6	6					
9	GB/T5783-M6x30	六角螺栓M6x30	BOLT M6x30	4					
10	F2.6-01050200	锁紧块组件	LOCKED BLOCK ASSY	1					
11	F2.6-01000003	旋转支架衬套A	BUSHING A	1					
12	F2.6-01000004	旋转支架衬套B	BUSHING B	1					
13	F2.6-01050100	锁紧手柄组件	LOCKED HANDLE ASSY	1					
14	F2.6-01040100	承推减震器	DAMPER	1					
15	F2.6-01040001	承推托架	BRACKET ,THRUST RECEIVE	1					
16	F2.6-01030007	起翘块	LEVER	1					
17	F2.6-01030100-A	角度锁紧手柄组件	TILT CLAMP HANDLE ASSY	1					
18	F4-01090006	衬套	BUSHING	2					
19	F2.6-01030003-A	角度锁紧手柄钮簧	SPRING	1					
20	F2.6-01030004-A	角度定位件	LEVER, TILT LOCK	1					
21	GB/T879.2-2x10	轻型直槽弹性圆柱销Φ2x10	PIN φ 2x10	2					
22	GB/T7940.1-M6	直通式压注油杯M6	NIPPLE, GREASE M6	1					
23	F2.6-01030001	旋转支架座	BRACKET, SWIVEL	1					
24	F2.6-01030005-A	定位件连杆	ROD, TILT LOCK	1					
25	GB/T896-3.5	开口档圈3.5	CLIP 3.5	1					
26	F2.6-01030006	起翘块销轴	PIN	1					
27	F2.6-01000001	六角螺栓M8x135	BOLT	1					
28	GB/T6172.1-M8	六角薄螺母M8	NUT M8	1					
29	GB/T6170-M8	六角螺母M8	NUT M8	1					
30	GB/T96-8	大垫圈8	WASHER 8	2					
31	F2.6-01010000	左夹紧托架组件	BRACKET LEFT ASSY	1					
32	F2.6-01020000	右夹紧托架组件	BRACKET RIGHT ASSY	1					
33	F4-01010005	舰板夹紧手柄铆钉	RIVET	2					
34	F4-01010002	舰板夹紧螺杆	CLAMP BOLT	2					
35	F4-01010004	舰板夹紧手柄	CLAMP SHIPBOARD HANDLE	2					
36	F4-01010003	舰板夹紧圆盘	CLAMP PLATE	2					
37	F2.6-01000002	螺栓垫管	BUSH ,BOLT	1					
38	GB/T889.1-M6	非金属嵌件六角锁紧螺母M6	NUT M6	1					
39	F2.6-01010001	左夹紧托架	BRACKET, CLAMP (LEFT)	1					
40	F2.6-07000009	标贴9	MARK 9	1					
41	GB/T5782-M6x125	六角螺栓M6×125	BOLT M6x125	1					
42	F2.6-00000100	托架护盖组件	BRACKET COVER ASSY	1					
43	F2.6-01040000	承推托架组件	THRUST RECEIVE ASSY	1					
44	F2.6-00000102	护盖衬管	BUSH	1					
45	F2.6-01030009	角度手柄衬圈	WASHER, CLAMP HANDLE	1					
46	GB/T896-6	开口挡圈 6	CIRCLIP 6	1					
47	F2.6-01030200	起翘摆杆	TILT BAR	1					
48	F2.6-01030008	起翘摆杆钮簧	SPRING, TILT BAR	1					
49	GB/T97.1-8	平垫圈 8	WASHER 8	1					

零部件名称:

操舵系统

PARTS NAME:

STEERING

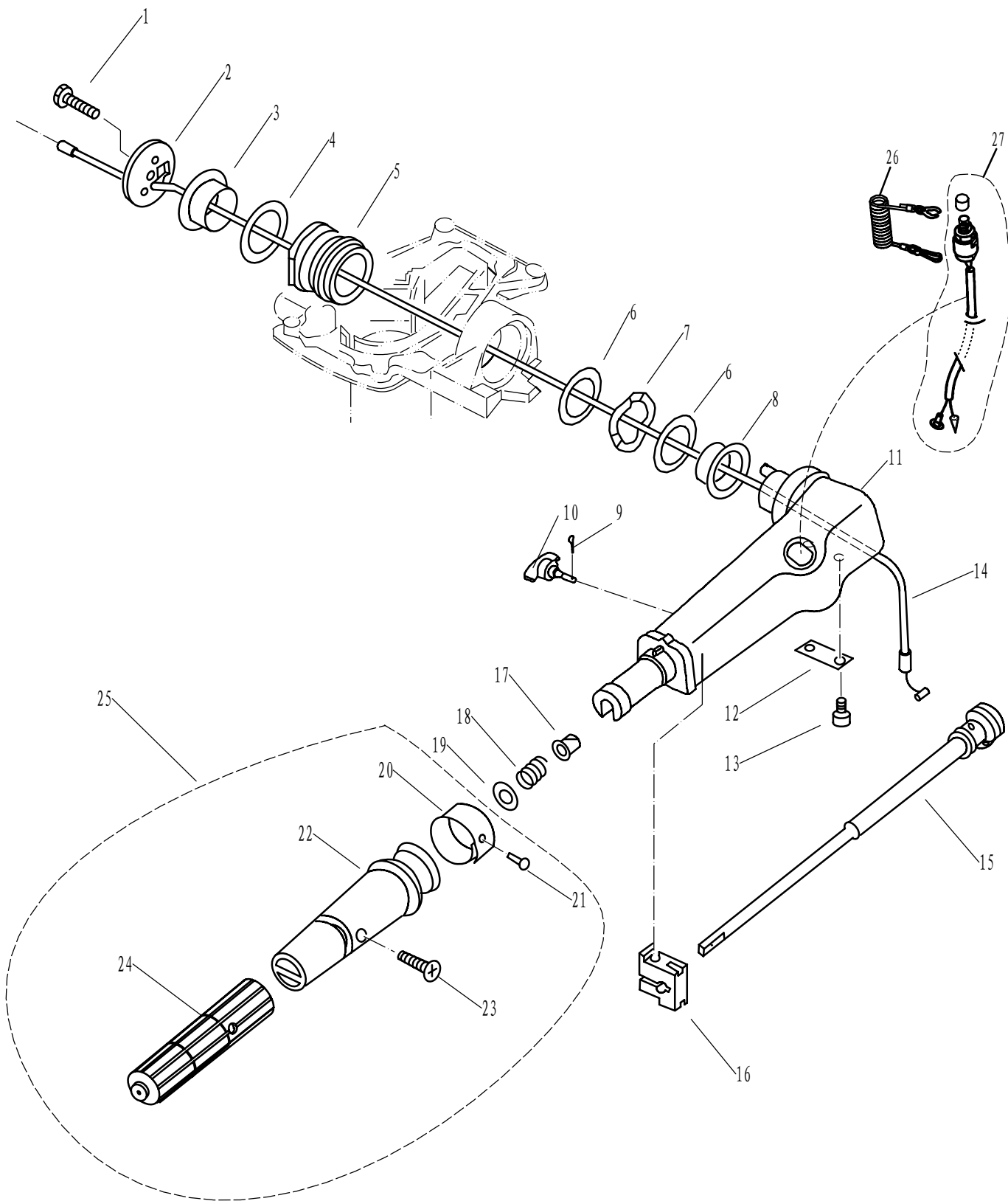

零部件名称:

水上装置壳体

PARTS NAME:

UPPER CASING

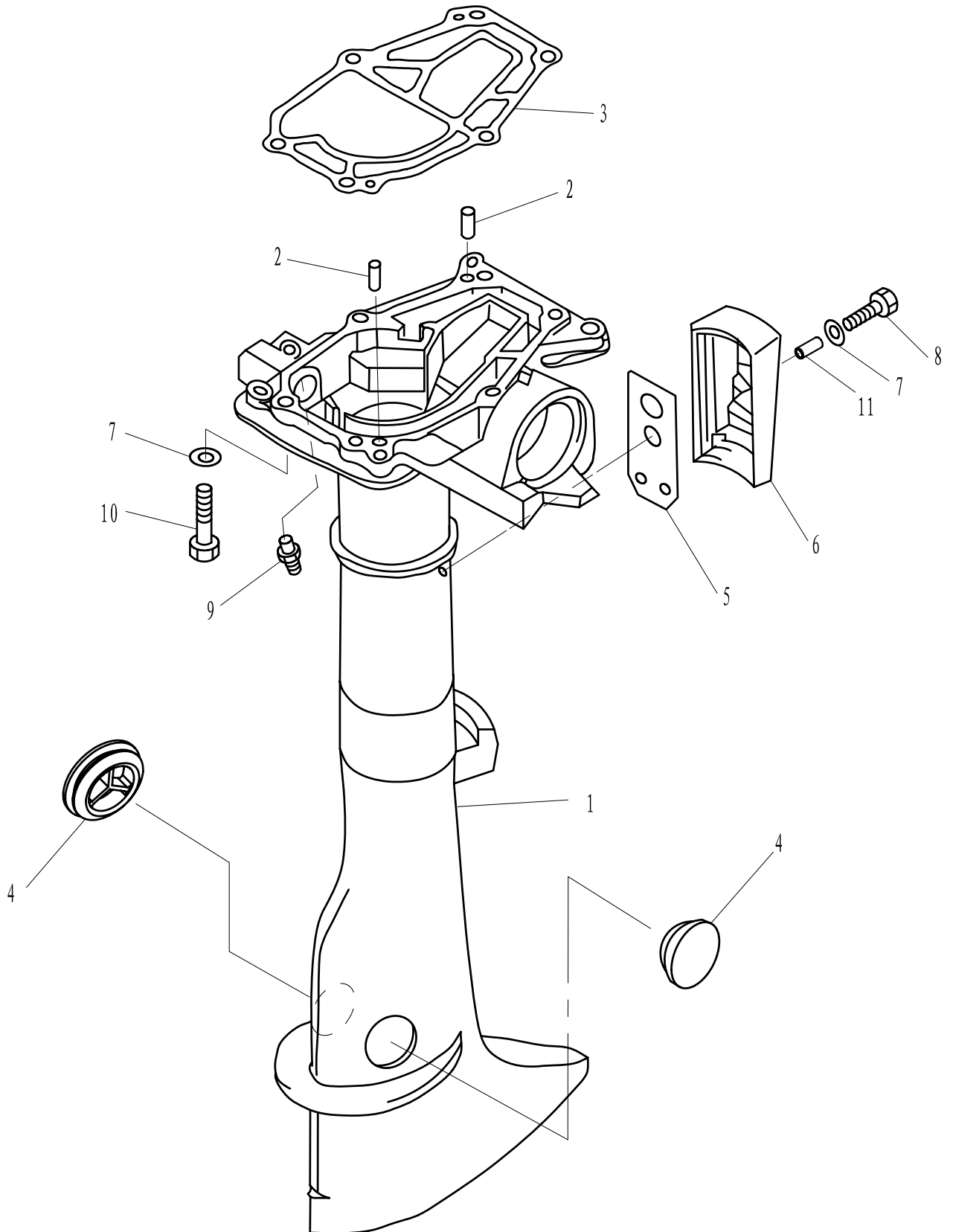

零部件名称:

水下装置壳体 and 驱动系统1

PARTS NAME:

LOWER CASING & DRIVE 1

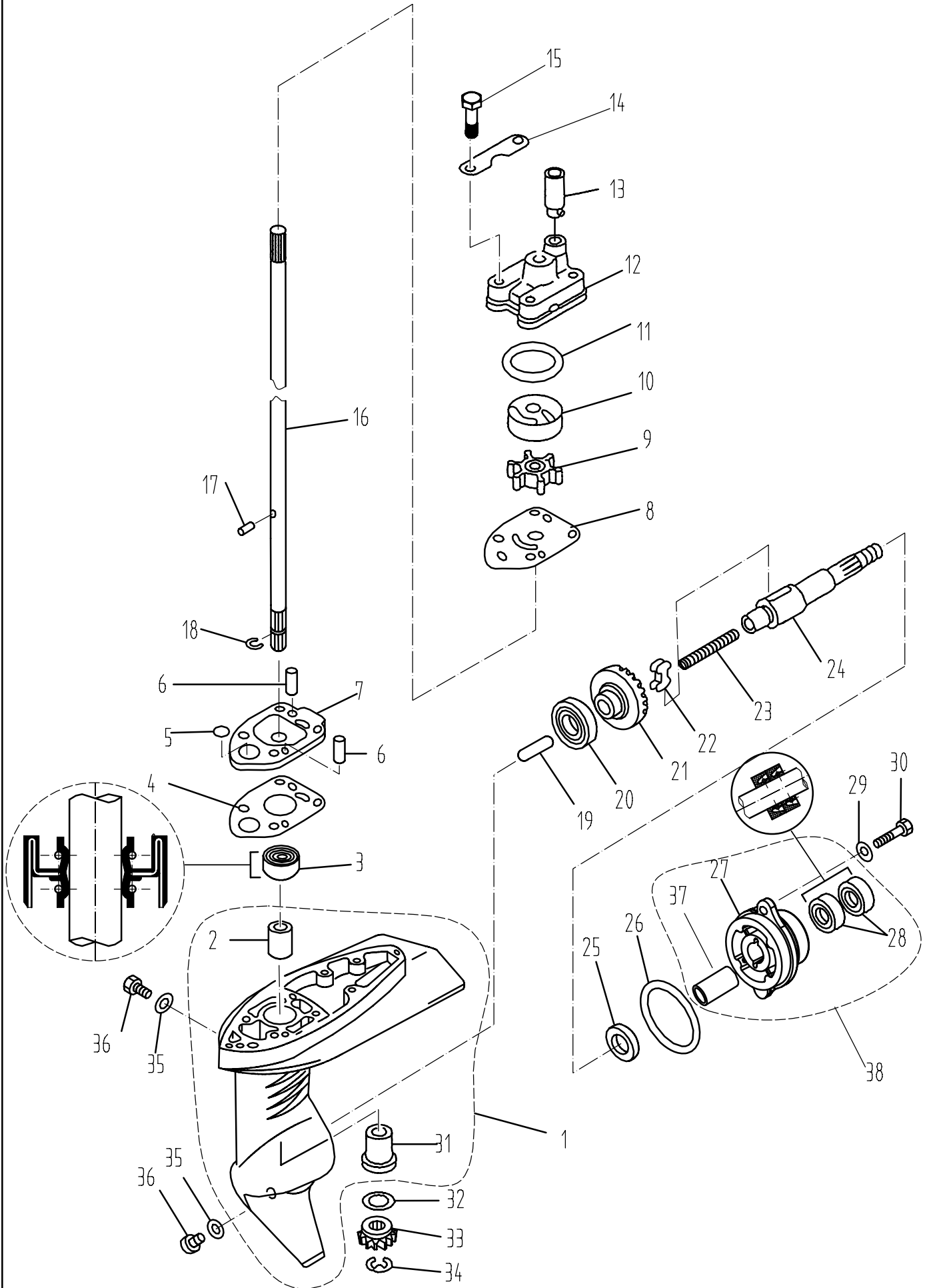

零部件名称:

水下装置壳体 and 驱动系统2

PARTS NAME:

LOWER CASING & DRIVE 2

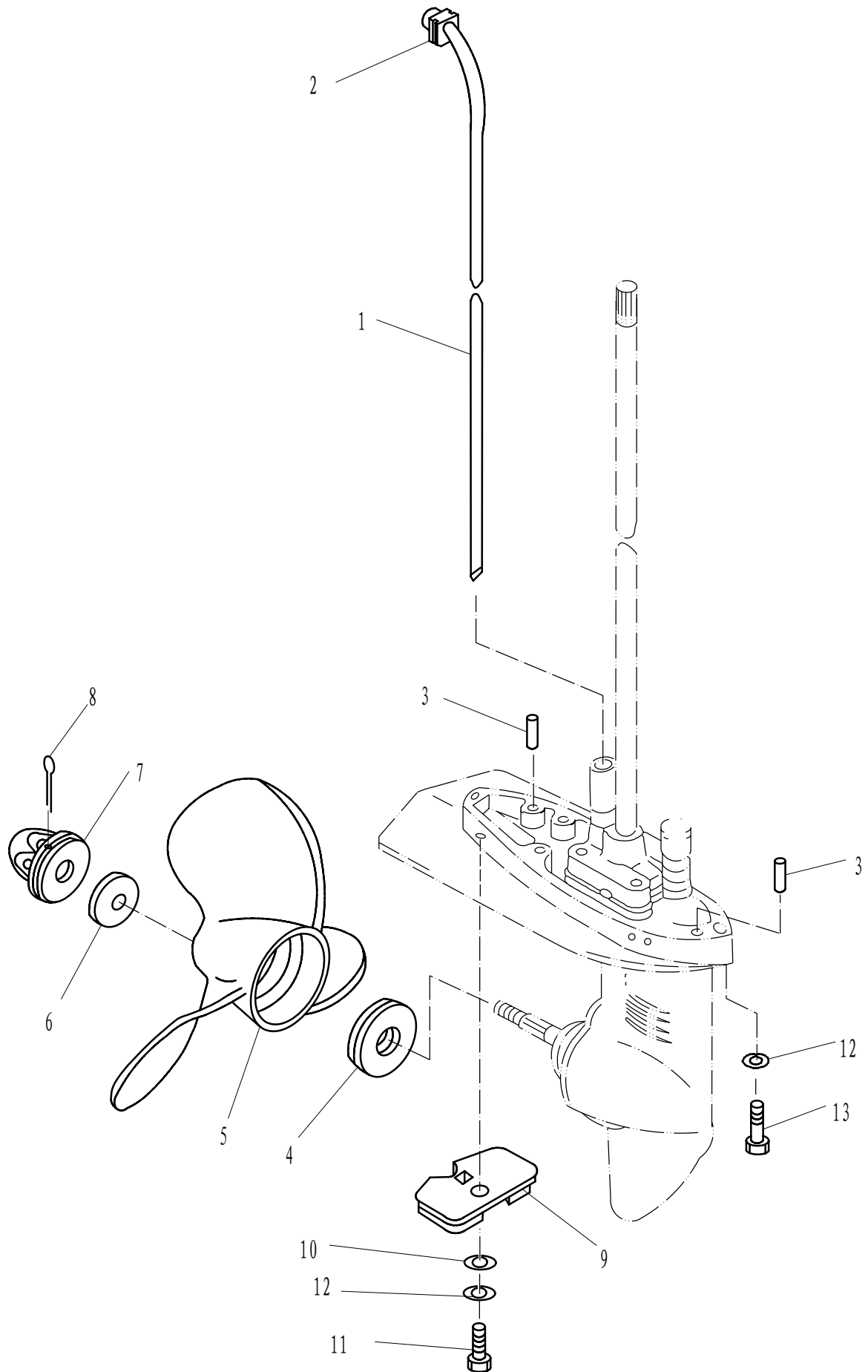

零部件名称:

气缸 & 曲轴箱1

PARTS NAME:

CYLINDER & CRANKCASE 1

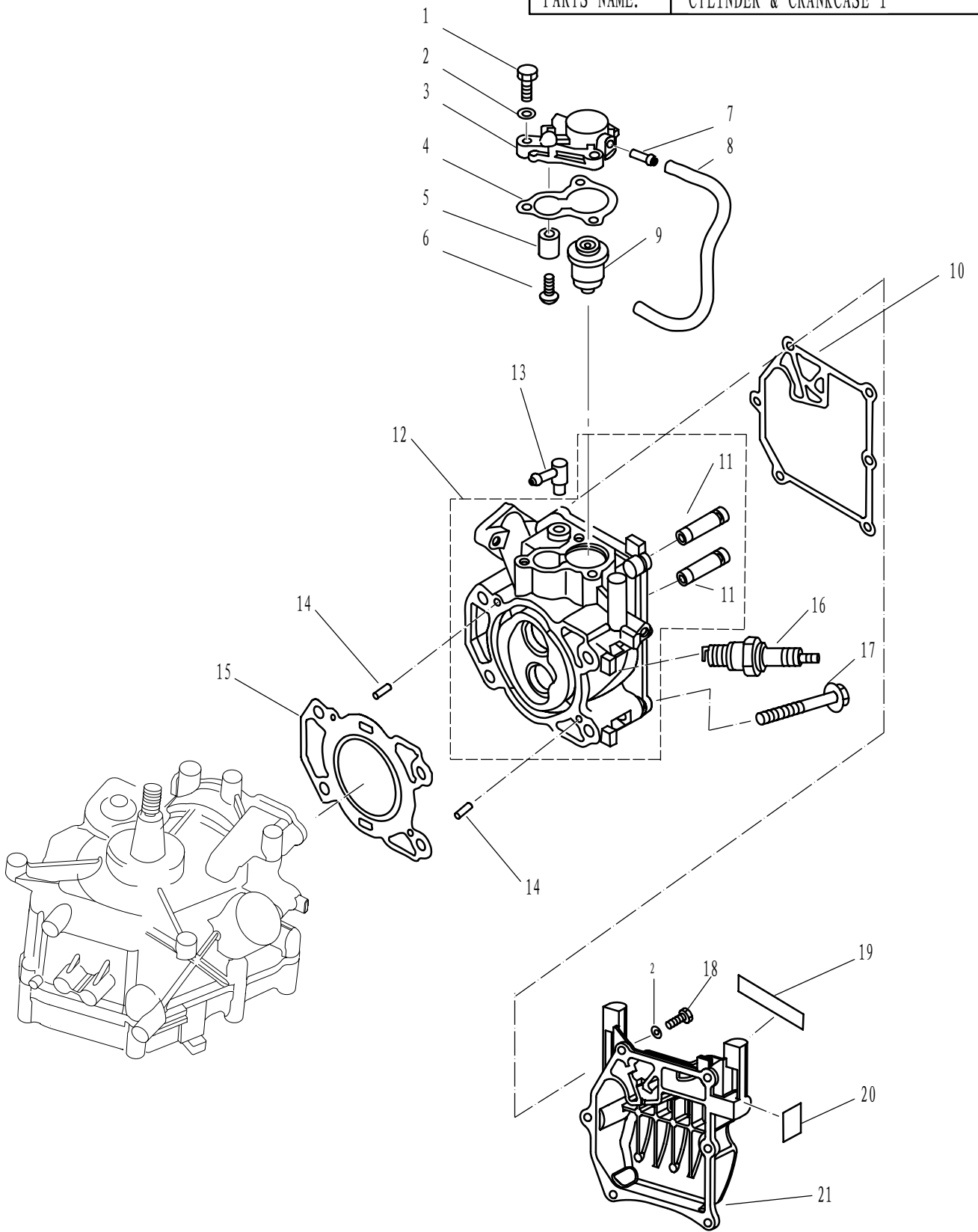

零部件名称:

气缸和曲轴箱 2

PARTS NAME:

CYLINDER & CRANKCASE 2

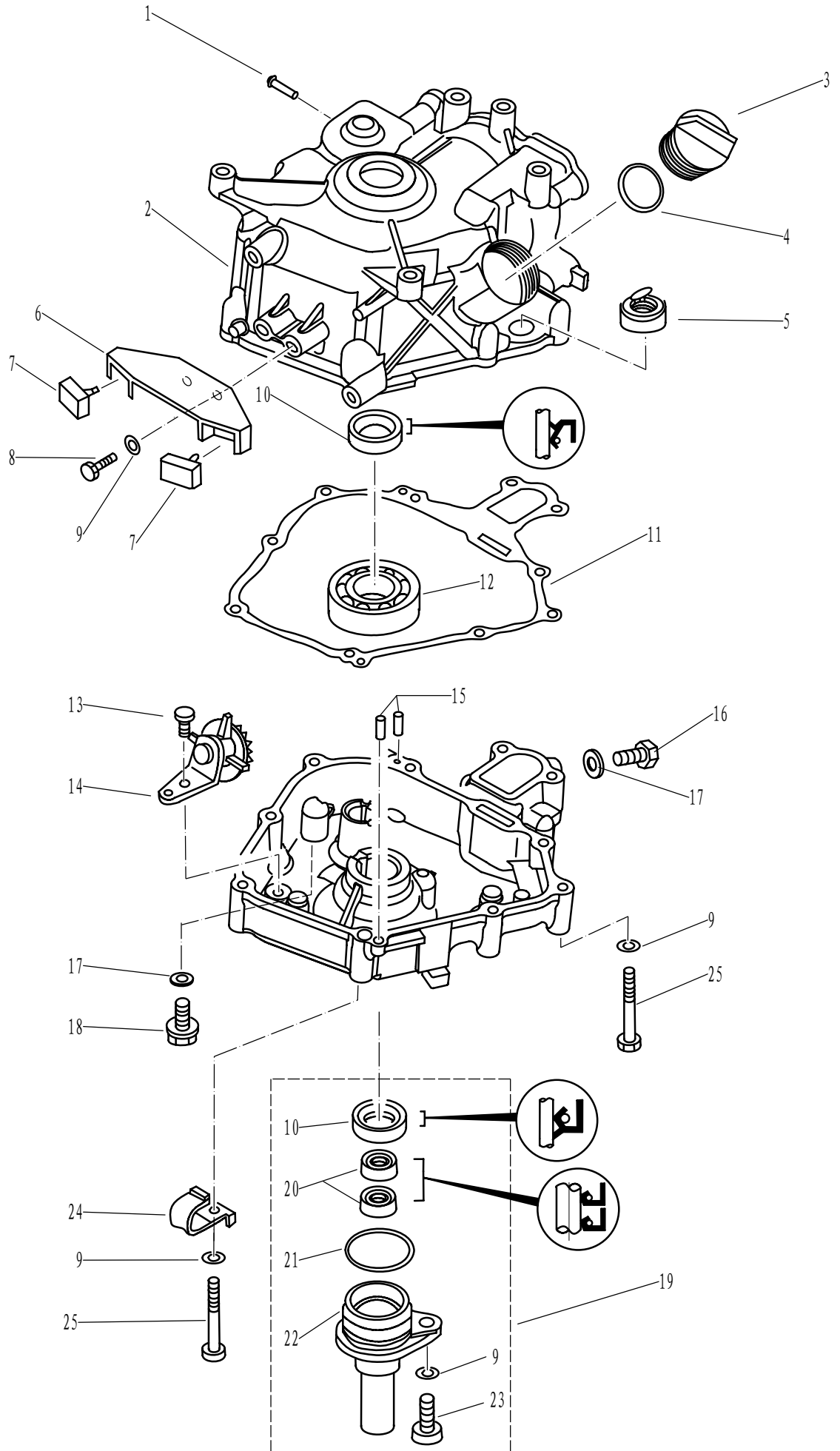

零部件名称:

燃油系统

PARTS NAME:

FUEL

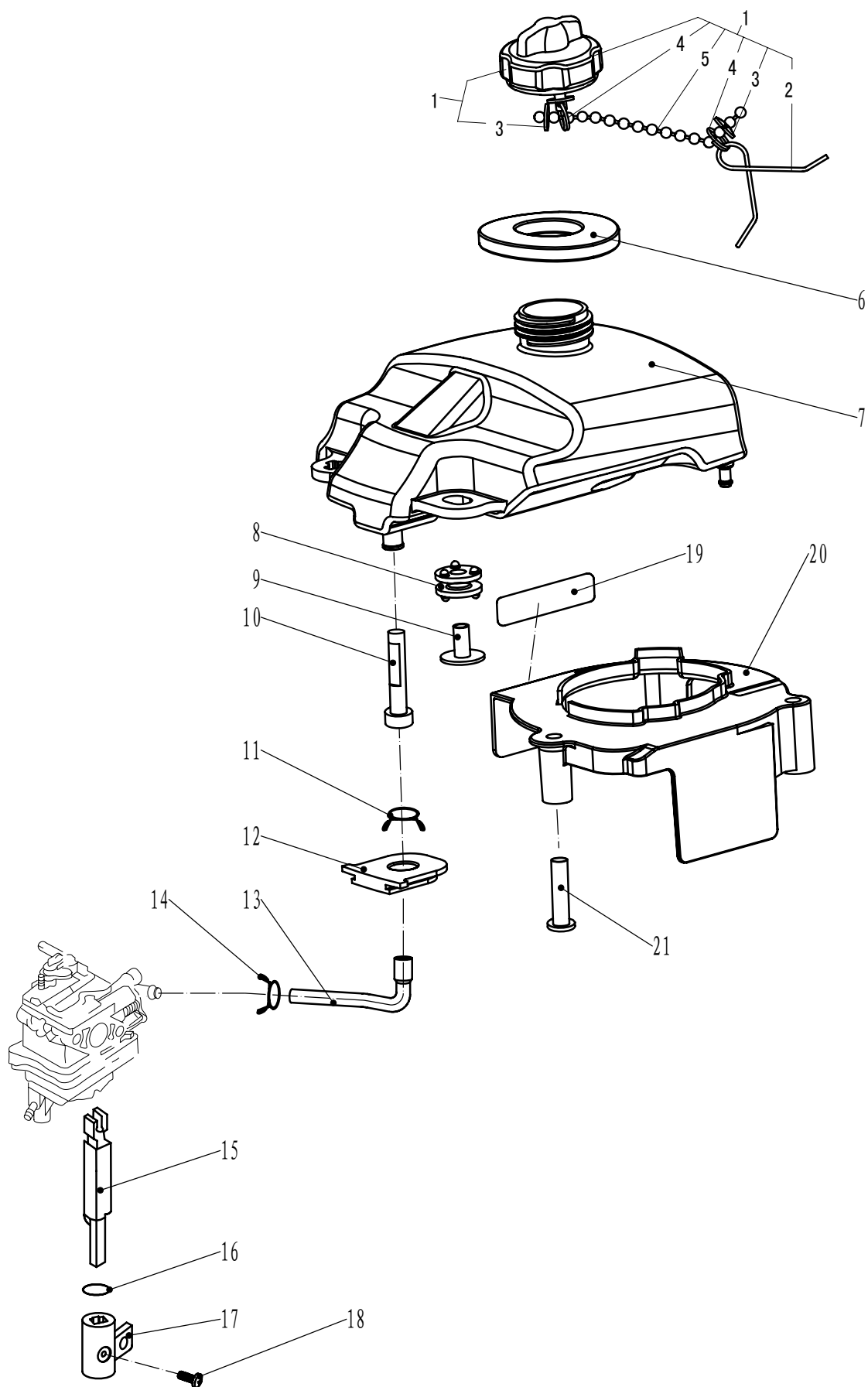

零部件名称:	底罩
PARTS NAME:	BOTTOM COWLING

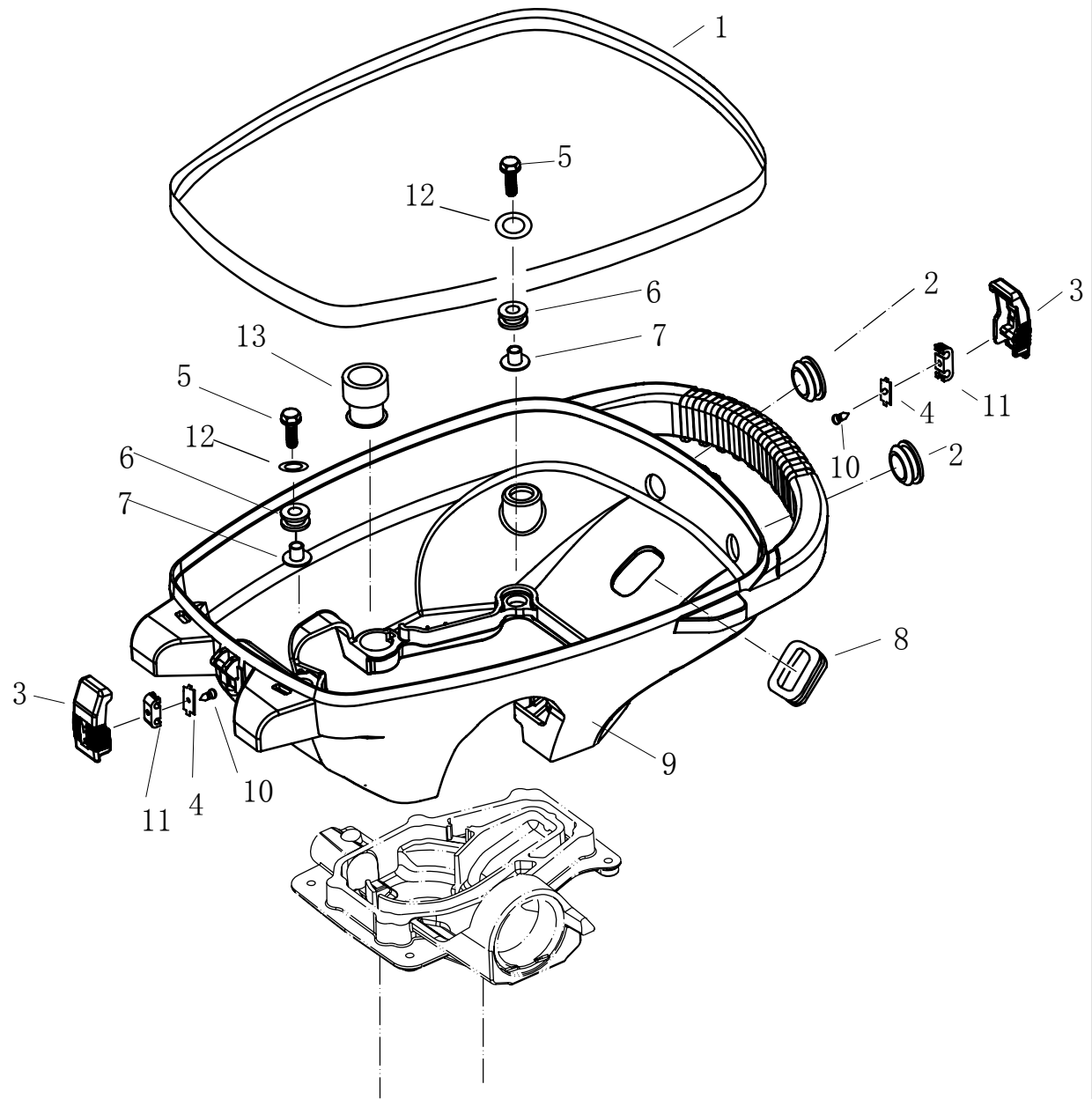

SN. 参照号码	PART NO. 零件编号	DESCRIPTION 零件名称(中文)	DESCRIPTION 零件名称(英文)	QTY 数量				REMARKS 备注
1	F2.6-05000002	底罩密封条	SEAL, BOTTOM COWLING	1				
2	F2.6-05000004	圆形闷头	RUBBER PLUG, CIRCULAR	2				
3	F2.6-05000008	顶罩锁紧钩	HOOK, LOCKING	2				
4	F2.6-05000010	金属连接杆	METALLIC LINK ROD	2				
5	GB/T5783-M6X25	六角螺栓M6X25	BOLT M6X25	4				
6	F2.6-05000006	底罩减震圈	DAMPER	4				
7	F2.6-05000007	凸缘垫管	TUBE FLANGE	4				
8	F2.6-05000003	长方形橡胶闷头	RUBBER PLUG, QUADRATE	1				
9	F2.6-05000001	底罩	BOTTOM COWLING	1				
10	GB/T845-ST2.9x5	十字槽盘头自攻螺钉ST2.9X5	SCREW, TAPPING ST2.9x5	2				
11	F2.6-05000009	锁紧钩连接件	CONNECTER-ROD	2				
12	GB/T96-6	平垫圈6	WASHER 6	4				
13	F2.6-05000005	放油口胶套	RUBBER LOVER	1				

零部件名称:

修理套件 1

PARTS NAME:

REPAIR KIT 1

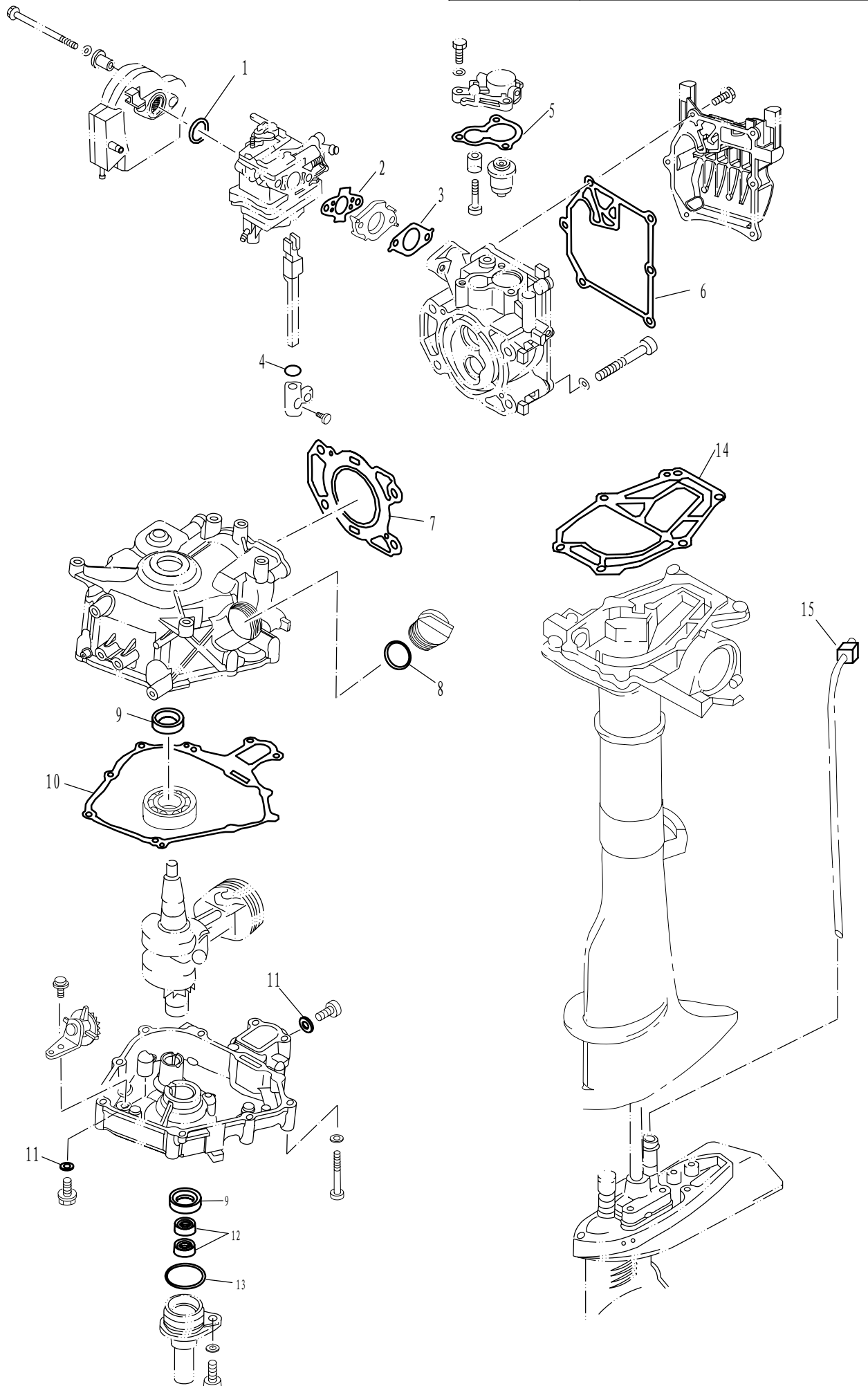

零部件名称:

修理套件2

PARTS NAME:

REPAIR KIT 2

