

<http://www.parsun.com.cn>

PARSUN

2009

百胜

零件目录

PARTS CATALOGUE

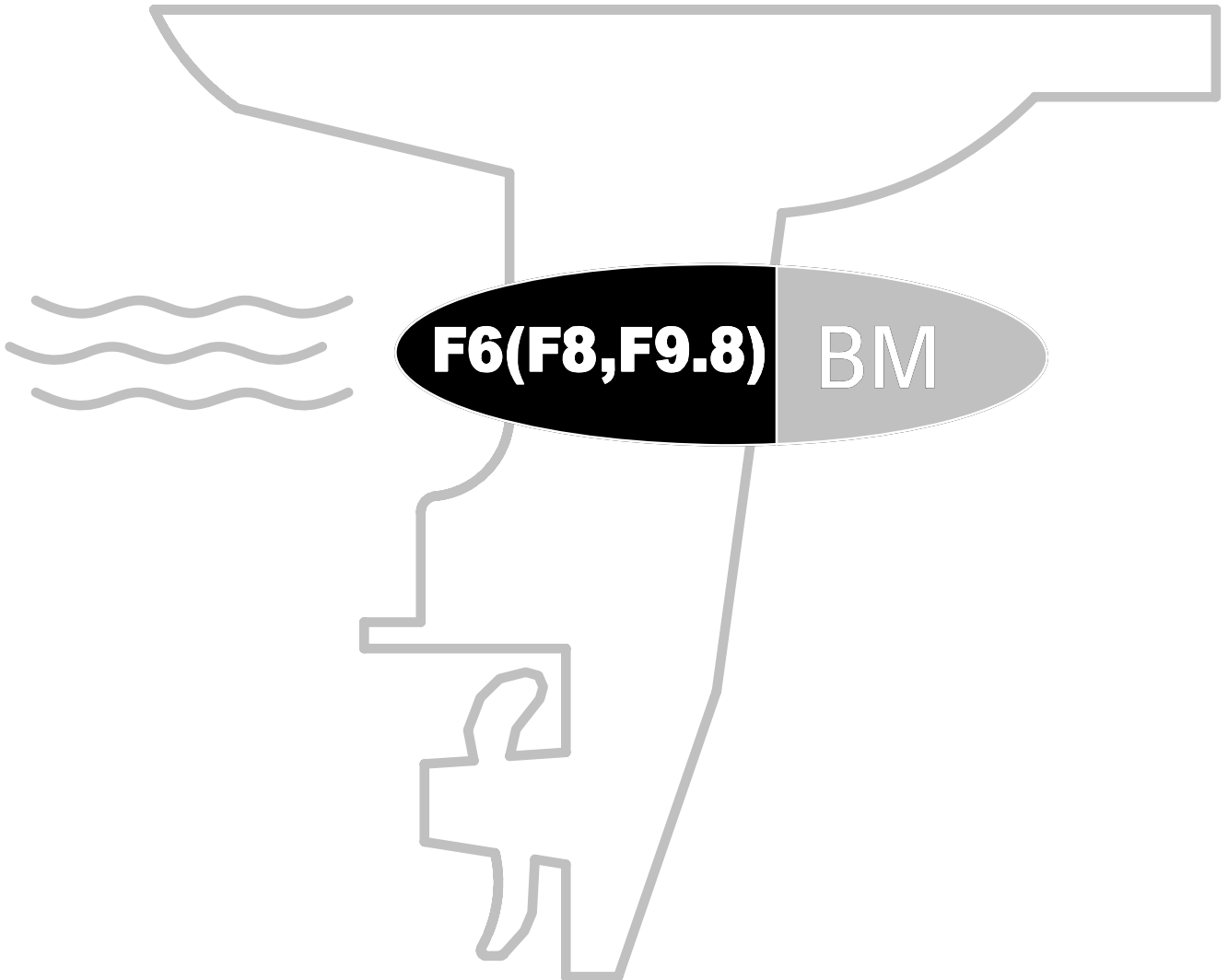

苏州百胜动力机器有限公司

SUZHOU PARSUN POWER MACHINE CO., LTD

目次

CONTENTS

托架	— — — — —	1 ~ 2
BRACKET	— — — — —	1 ~ 2
操舵系统	— — — — —	3 ~ 4
STEERING	— — — — —	3 ~ 4
水上装置壳体	— — — — —	5 ~ 6
UPPER CASING	— — — — —	5 ~ 6
底罩	— — — — —	7 ~ 8
BOTTOM COWLING	— — — — —	7 ~ 8
控制系统	— — — — —	9 ~ 10
CONTROL SYSTEM	— — — — —	9 ~ 10
水下装置壳体&驱动系统	— — — — —	11 ~ 13
LOWER CASING & DRIVE	— — — — —	11 ~ 13
电气	— — — — —	14 ~ 15
ELECTRICAL	— — — — —	14 ~ 15
进气系统	— — — — —	16
INTAKE	— — — — —	16
气缸头	— — — — —	17
CYLINDER HEAD	— — — — —	17
曲轴&活塞	— — — — —	18
CRANKSHAFT & PISTON	— — — — —	18
曲轴箱	— — — — —	19 ~ 20
CRANKCASE	— — — — —	19 ~ 20
阀门	— — — — —	21
VALVE	— — — — —	21
凸轮轴	— — — — —	22
CAMSHAFT	— — — — —	22
燃油系统	— — — — —	23
FUEL SYSTEM	— — — — —	23
起动器	— — — — —	24 ~ 25
STARTER	— — — — —	24 ~ 25
顶罩组件	— — — — —	26 ~ 27
TOP COWLING ASSY	— — — — —	26 ~ 27
燃油箱	— — — — —	28
FUEL TANK	— — — — —	28
气缸头总成(修理件)	— — — — —	I ~ II
CYLINDER HEAD ASSY (REPAI KIT)	— — — — —	I ~ II
发动机头总成(修理件)	— — — — —	III ~ IV
ENGINE ASSY (REPAI KIT)	— — — — —	III ~ IV
附录1(修理件)	— — — — —	V ~ VI
APPENDIX 1 (REPAI KIT)	— — — — —	V ~ VI
附录2(修理件)	— — — — —	VII ~ VIII
APPENDIX 2 (REPAI KIT)	— — — — —	VII ~ VIII

零部件名称: 托架

PARTS NAME: BRACKET

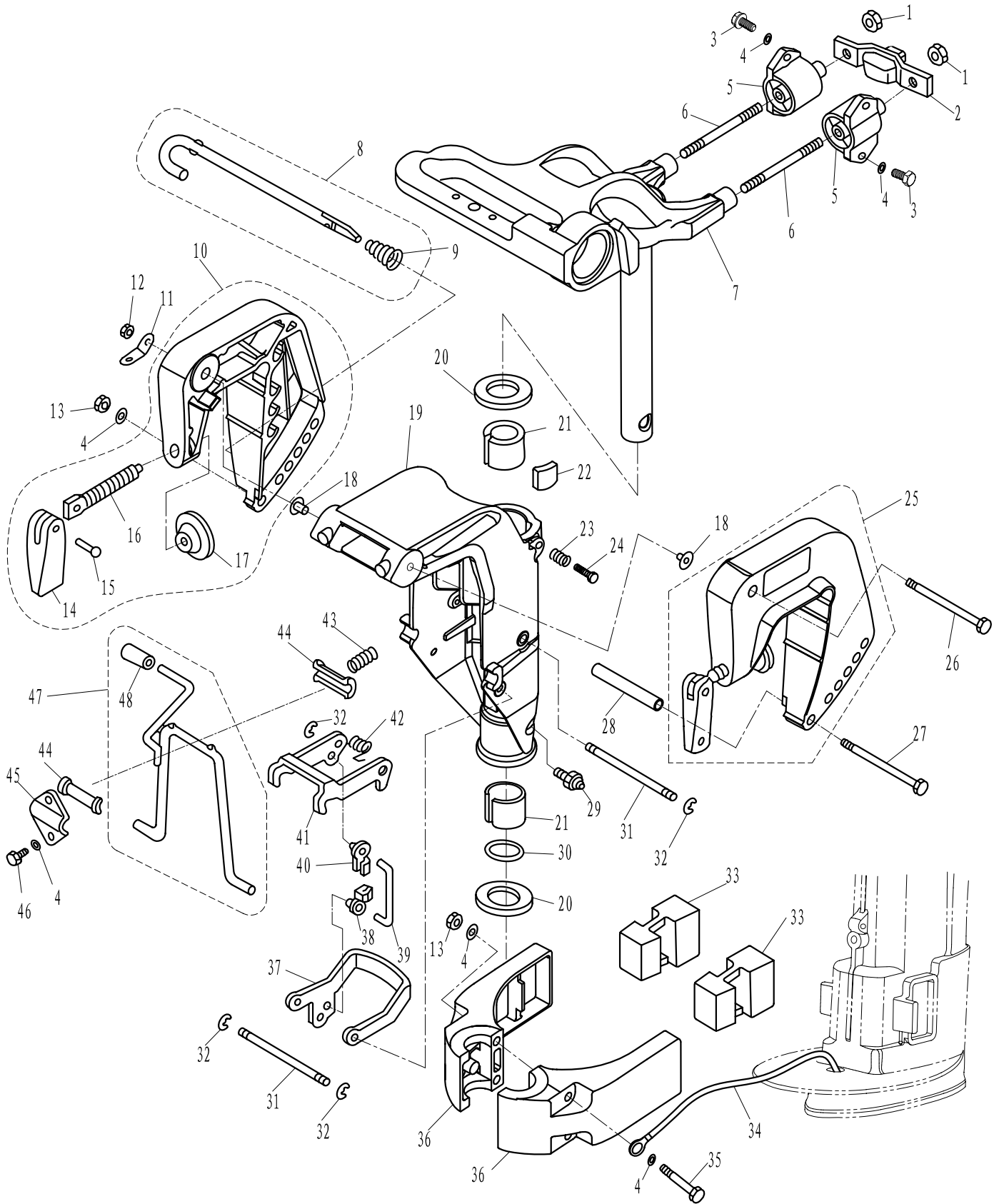

SN. 参照号码	PART NO. 零件编号	DESCRIPTION 零件名称 (中文)	DESCRIPTION 零件名称 (英文)	QTY 数量				REMARKS 备注
1	GB/T889.1-M8	I型非金属嵌件六角锁紧螺母 M8	NUT M8	2				
2	F8-00000100	前减震块	ABSORBER (FRONT)	1				
3	GB/T5783-M6X20	六角螺栓 M6X20	BOLT M6x20	4				
4	GB/T97.1-6	平垫圈 6	WASHER 6	11				
5	F8-02000100	减震器组件	ABSORBER ASSY	2				

零部件名称:

托架

PARTS NAME:

BRACKET

SN. 参照号码	PART NO. 零件编号	DESCRIPTION 零件名称 (中文)	DESCRIPTION 零件名称 (英文)	QTY 数量					REMARKS 备注
6	F8-01000003	双头螺栓 M8X65	DICEPHALOUS BOLT M8X65	2					
7	F8-01020000	操舵托架组件	STEER BRACKET ASSY	1					
8	F8-01010200	角度调整杆组件	THRUST ROD ASSY	1					
9	F4-01050002	锥形弹簧	CONICAL SPRING	1					
10	T6-01010400	夹紧托架 (左) 组件	BRACKET ASSY (LEFT)	1					
11	F4-01000002	双孔固定板	PLATE, TWO HOLE	1					
12	GB/T889.1-M8	非金属嵌件六角螺母 M8	NUT M8	1					
13	GB/T6170-M6	六角螺母 M6	NUT M6	3					
14	F4-01010004	艀板夹紧手柄	CLAMP HANDLE, STERN	2					
15	F4-01010005	艀板夹紧手柄铆钉	RIVET, CLAMP HANDLE	2					
16	F4-01010002	艀板夹紧螺杆	CLAMP SCREW	2					
17	F4-01010003	艀板夹紧圆盘	CLAMP PAD	2					
18	F4-01000003	尼龙垫圈	WASHER, NYLON	2					
19	F8-01010101	旋转支架	ROTARY BRACKET	1					
20	F8-01000001	旋转支架垫圈	WASHER, ROTARY BRACKET	2					
21	F8-01000002	旋转支架衬套	BUSHING, ROTARY BRACKET	2					
22	F8-01000100	锁紧块组件	LOCKING BLOCK ASSY	1					
23	F8-01010102	锁紧弹簧	SPRING, LOCKING	1					
24	GB/T5783-M8X30	六角螺栓 M8X30	BOLT M8X30	1					
25	T6-01010300	夹紧托架 (右) 组件	BRACKET ASSY (RIGHT)	1					
26	GB/T5782-M8X140	六角螺栓 M8X140	BOLT M8X140	1					
27	GB/T5782-M6X130	六角螺栓 M6X130	BOLT M6X130	1					
28	F8-01010001	螺栓垫管	TUBE, BOLT	1					
29	JB/T7940.1-M6	直通式压注油杯 M6	OILER M6	1					
30	JASO F404 35-022	O型圈 $\phi 22.4 \times \phi 3.5$	O-RING $\phi 22.4 \times \phi 3.5$	1					
31	F8-01010108	旋转支架销轴	SHAFT, ROTARY BRACKET	2					
32	GB/T896-5	开口挡圈 5	CIRCLIP 5	4					
33	F8-00000002	减震块	ABSORBER	2					
34	T15-02010100	接地钢索 B	TIGHTWIRE B	1					
35	GB/T5782-M6X75	六角螺栓 M6X75	BOLT M6X75	2					
36	F8-00000001	减震块外壳	SHELL, ABSORBER	2					
37	F8-01010106	旋转支架外架	OUTER FRAME, ROTARY BRACKET	1					
38	F8-01010112	外架连杆接头	TIE-IN, CONNCTING ROD	1					
39	F8-01010110	内架连杆	CONNCTING ROD, INNER FRAME	1					
40	F8-01010111	内架连杆接头	TIE-IN, CONNCTING ROD	1					
41	F8-01010107	旋转支架内架	INNER FRAME, ROTARY BRACKET	1					
42	F8-01010109	内架扭簧	SPRING, WREST	1					
43	F8-01010104	支撑架弹簧	SPRING, SUPPORT	1					
44	F8-01010103	支撑架尼龙衬套	BUSHING	2					
45	F8-01010105	支撑架压板	PRESS PLATE	1					
46	GB/T5783-M6X12	六角螺栓 M6X12	BOLT M6X12	2					
47	F8-01010300	角度定位支撑架组件	SUPPORT ASSY	1					
48	F4-01030103	手柄套	HANDLE COVER	1					

零部件名称: 操舵系统

PARTS NAME: STEERING

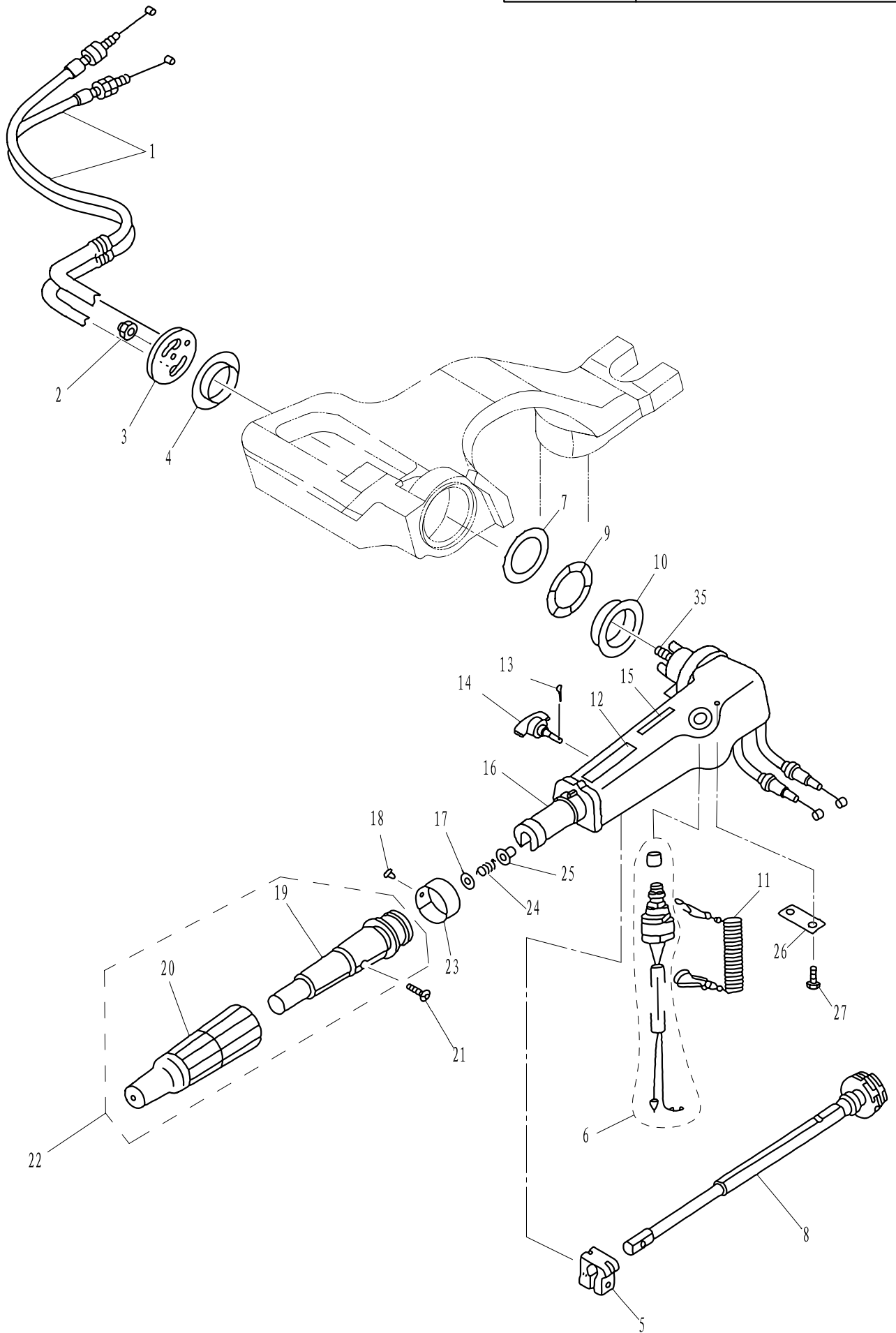

零部件名称: 水上装置壳体

PARTS NAME: UPPER CASING

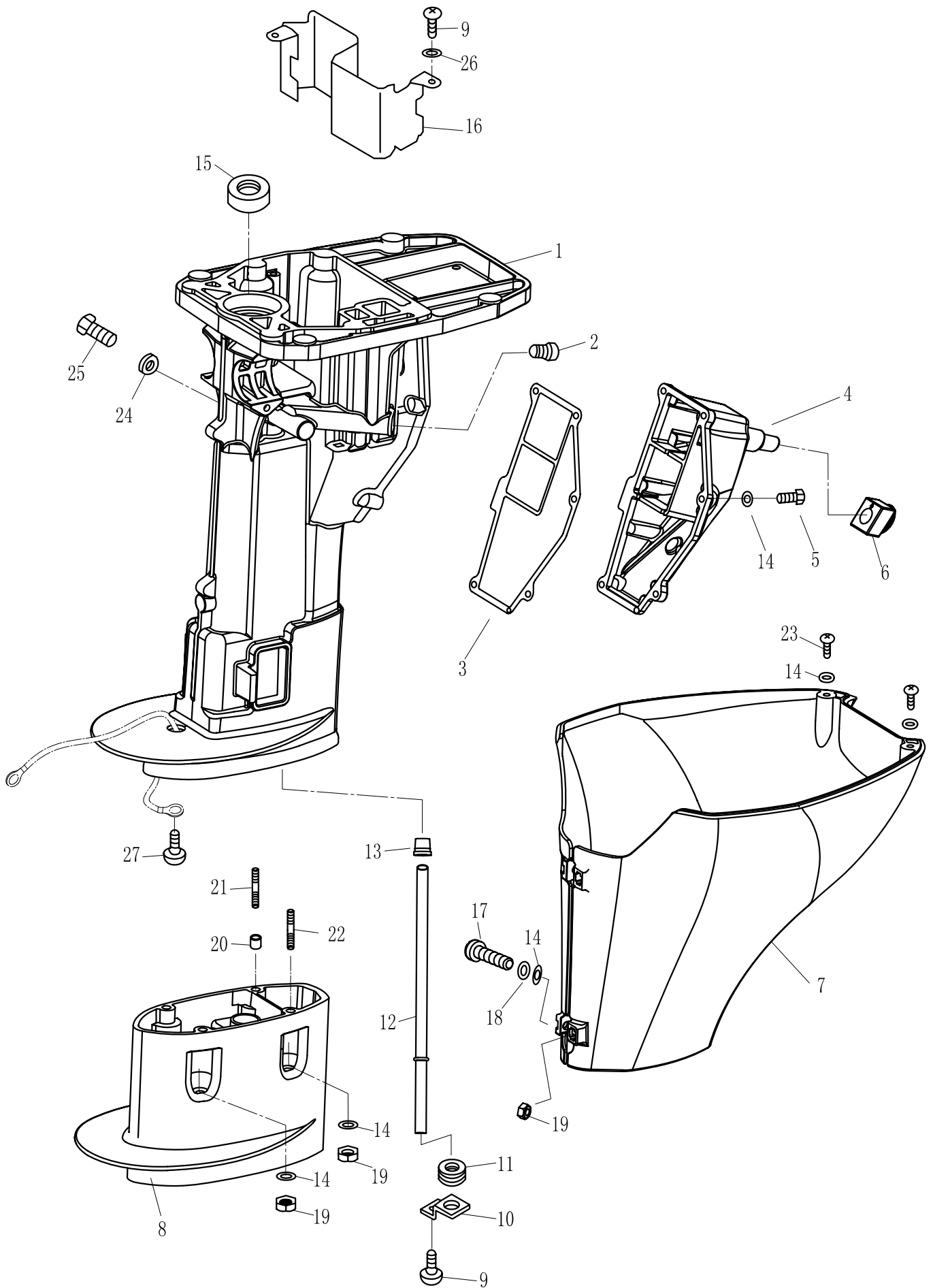

零部件名称:

底罩

PARTS NAME:

BOTTOM COWLING

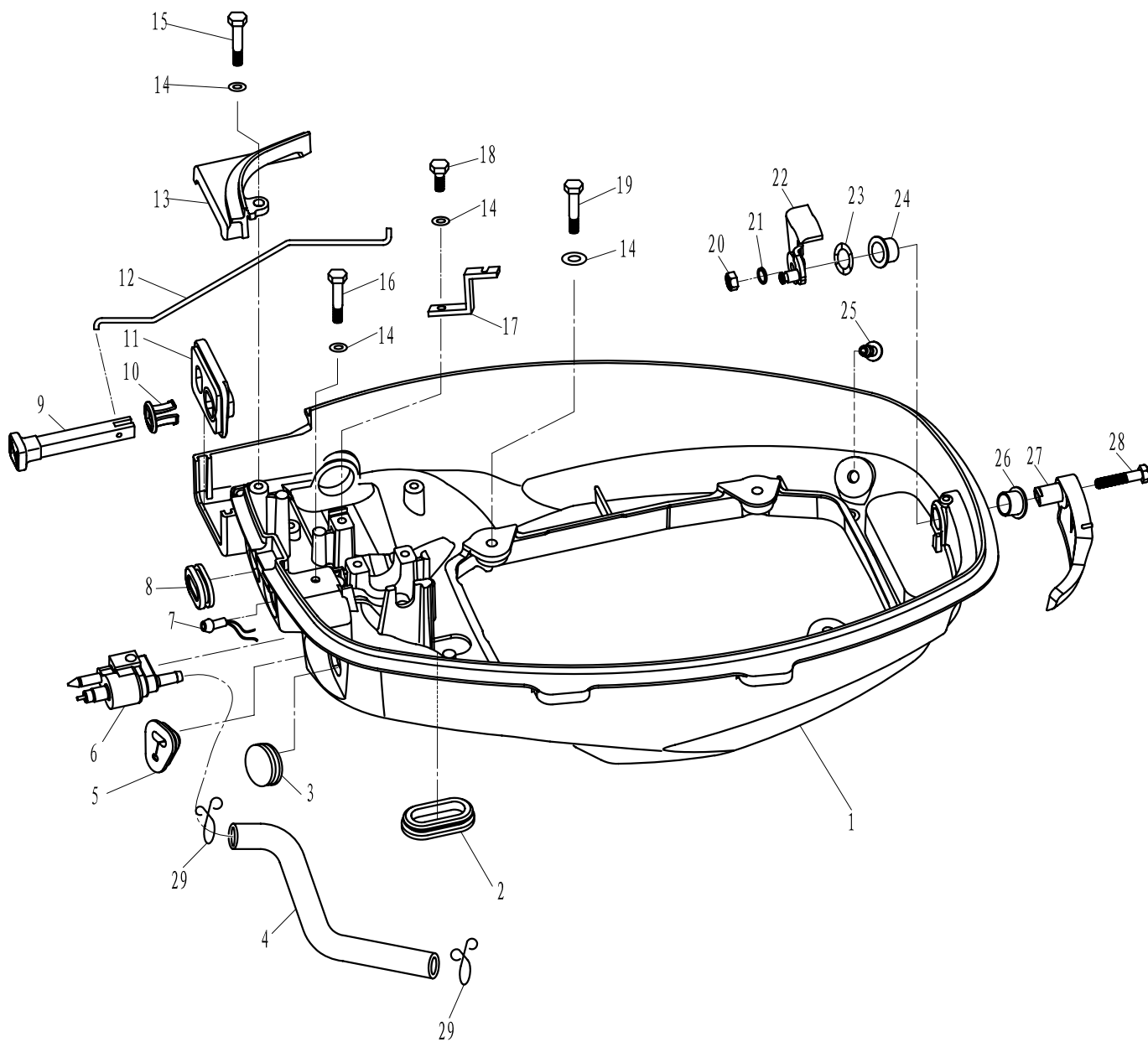

零部件名称: 控制系统

PARTS NAME: CONTROL SYSTEM

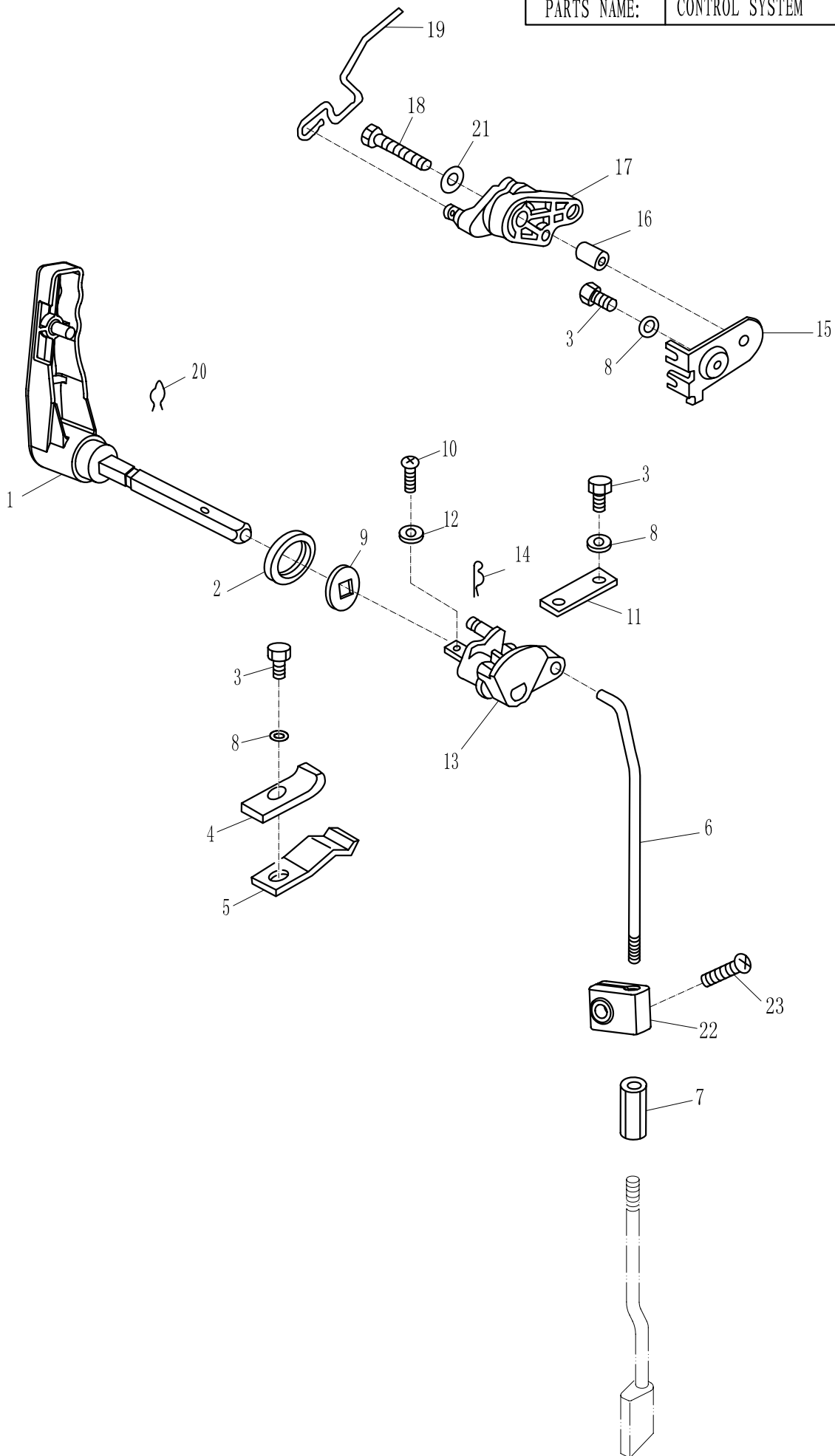

零部件名称: 水下装置壳体&驱动系统

PARTS NAME: LOWER CASING & DRIVE

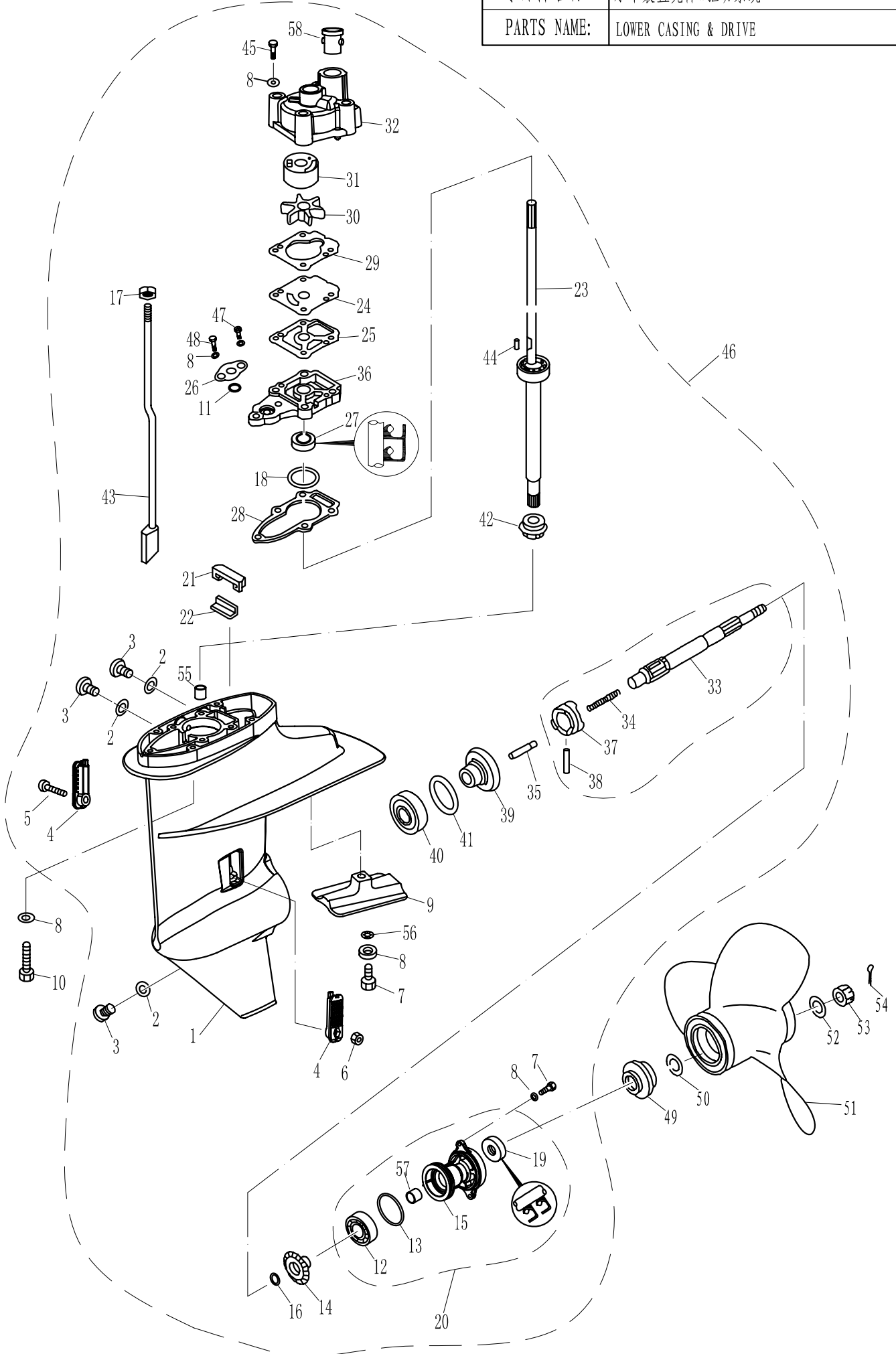

零部件名称: 水下装置壳体&驱动系统

PARTS NAME: LOWER CASING & DRIVE

SN. 参照号码	PART NO. 零件编号	DESCRIPTION 零件名称(中文)	DESCRIPTION 零件名称(英文)	QTY 数量					REMARKS 备注
1	F8-04000001	水下装置壳体	LOWER CASING	1					
2	F4-03000024	注油孔螺栓密封垫	GASKET	3					
3	F4-03000023	注油孔螺栓	PLUG, OIL HOSE	3					
4	F8-04000017	进水口	WATER INLET	2					
5	GB/T823-M4X25	十字槽小盘头螺钉 M4X25	SCREW M4X25	1					
6	GB/T889.1-M4	六角锁紧螺母 M4	NUT, HEXAGON M4	1					
7	GB/T5783-M6X25	六角螺栓 M6X25	BOLT, HEXAGON M6X25	3					
8	GB/T97.1-6	平垫圈6	WASHER 6	11					
9	F8-04000018	水下阳极	ANODE	1					
10	GB/T5783-M6X35	六角螺栓 M6X35	BOLT, HEXAGON M6X35	4					
11	F2.6-03000009	O形密封圈	O-RING	1					
12	GB/T276-6004	深沟球轴承6004	BEARING 6004	1					
13	F8-04040002	水下壳盖O形圈	O-RING	1					
14	F8-04000014	倒档齿轮	GEAR, REVERSE	1					
15	F8-04040001	水下壳体盖	COVER, LOWER CASING	1					
16	F8-04000012	倒档齿轮垫圈	WASHER	1					
17	GB/T6170-M5	六角螺母 M5	NUT, HEXAGON M5	1					
18	F8-04000004-1	驱动轴填隙片 0.10mm	SHIM 0.10mm						
	F8-04000004-2	驱动轴填隙片 0.15mm	SHIM 0.15mm						
	F8-04000004-3	驱动轴填隙片 0.20mm	SHIM 0.20mm						
19	F8-04040004	螺旋桨轴油封15X28X10	OIL SEAL	1					
20	F8-04040000	水下装置壳体盖组件	COVER ASSY, LOWER CASING	1					
21	F8-04000016	水封密封垫	GASKET, WATER SEAL	1					
22	F8-04000015	水封	WATER SEAL	1					
23	F8-04020001 (L)	驱动轴组件(L)	DRIVE SHAFT ASSY (L)	1					L
	F8-04020001 (S)	驱动轴组件(S)	DRIVE SHAFT ASSY (S)	1					S
24	F8-04000007	外挡板	OUTER PLATE	1					
25	F8-04000006	外挡板下密封垫	GASKET, OUTER PLATE	1					
26	F8-04000011	O形圈挡板	PLATE, O-RING	1					
27	F8-04000101	水泵座油封 12.1X24X8	OIL SEAL	1					
28	F8-04000005	水泵座密封垫	GASKET, WATER PUMP SEAT	1					
29	F8-04000008	外挡板上密封垫	GASKET, OUTER PLATE	1					
30	F8-04000200	水泵叶轮	IMPELLER	1					
31	F8-04000010	水泵内壳	INNER SHELL, WATER PUMP	1					
32	F8-04000009	水泵壳体	WATER PUMP	1					
33	F8-04000301	螺旋桨轴	SHAFT, PROPELLER	1					
34	F8-04000302	离合器弹簧	SPRING, CLUTCH	1					
35	F8-04000305	离合器销	PIN, CLUTCH	1					
36	F8-04000102	水泵座	WATER PUMP SEAT	1					
37	F8-04000303	爪形离合器	CLUTCH, DOG	1					
38	GB/T879.1-3.5X28	重型直槽弹性圆柱销 3.5X28	PIN 3.5X28	1					
39	F8-04010000	正档齿轮组件	GEAR, FORWARD	1					
40	GB/T276-6204	深沟球轴承 6204	BEARING 6204	1					

零部件名称: 电气

PARTS NAME: ELECTRICAL

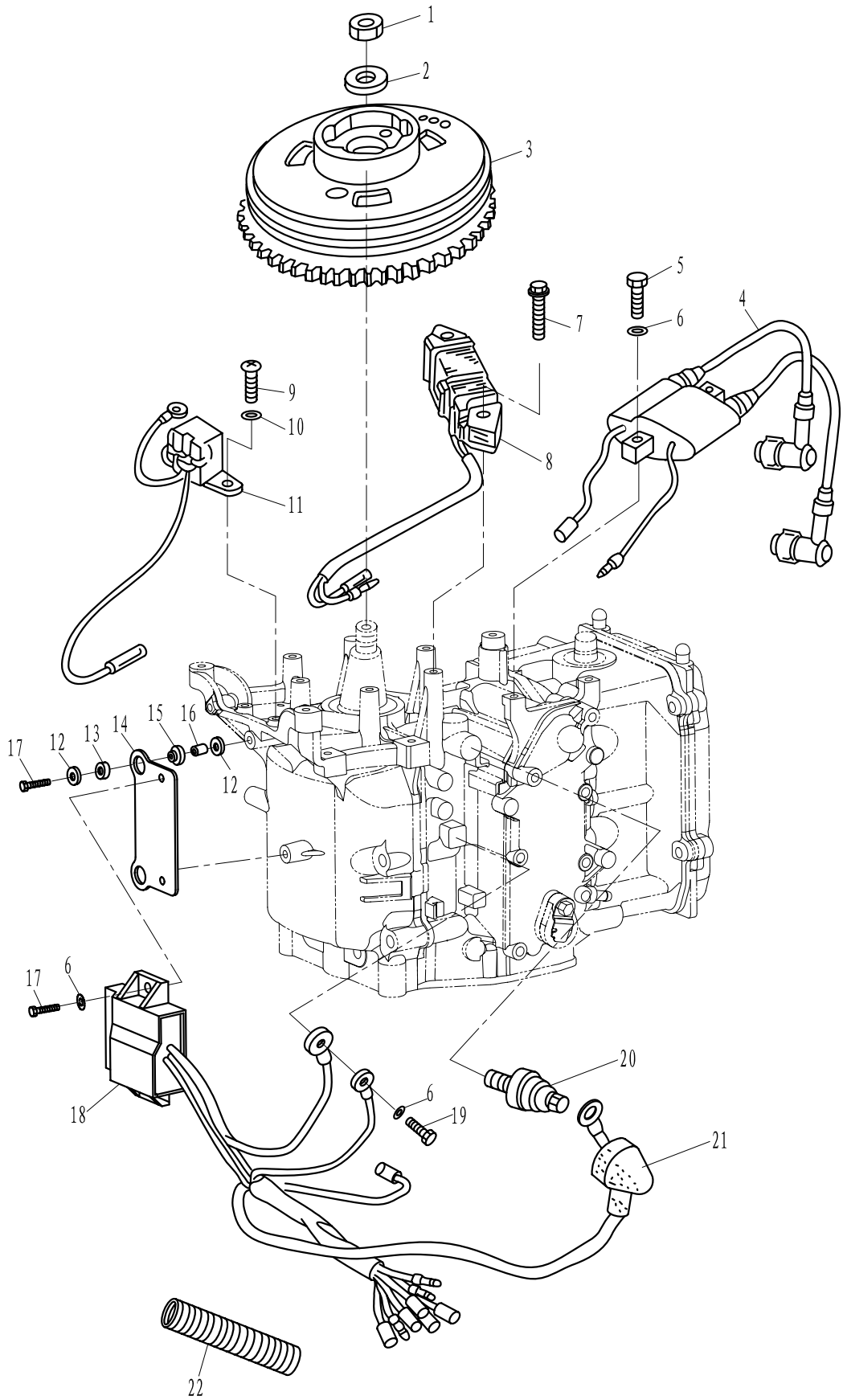

零部件名称:

气缸头

PARTS NAME:

CYLINDER HEAD

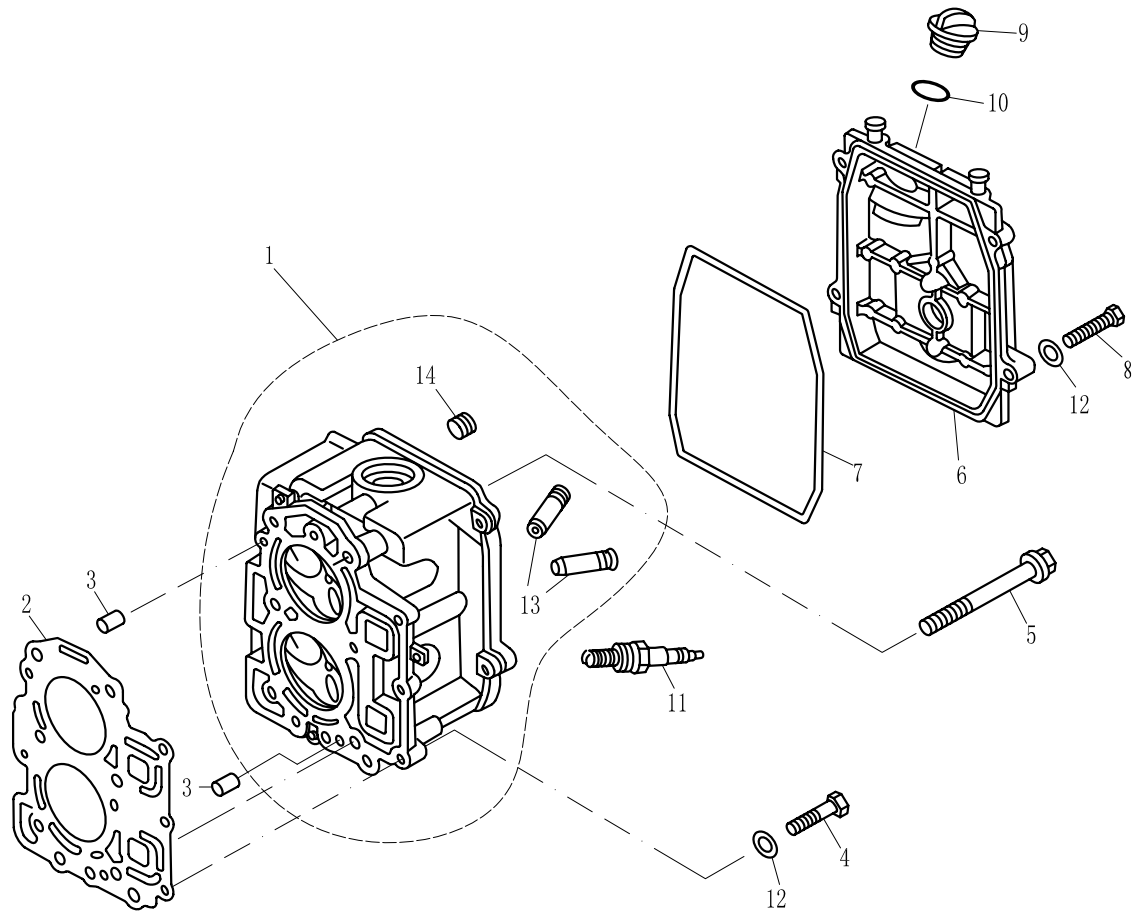

参照号码	PART NO. 零件编号	DESCRIPTION 零件名称(中文)	DESCRIPTION 零件名称(英文)	QTY 数量					REMARKS 备注
1	F8-05030100	气缸头组件	CYLINDER HEAD ASSY	1					
2	F8-05000100	气缸垫组件	CYLINDER HEAD GASKET	1					
3	F15-00000006	定位销 6x12	KNOCK 6x12	2					
4	F8-05000022	六角螺栓 M6x25	BOLT M6x25	3					
5	F4-04000039	六角凸缘螺栓 M8x50	BOLT M8x50	6					
6	F8-05000001	缸头罩	CYLINDER HEAD COVER	1					
7	F8-05000002	缸头罩密封圈	CYLINDER HEAD COVER GASKET	1					
8	GB/T5783-M6x25	六角螺栓 M6x25	BOLT M6x25	4					
9	F15-07050004	加油口盖	FILLER CAP, ENGINE OIL	1					
10	JASO F404 35 025	加油口盖密封圈	O-RING	1					
11	NGK DPR7HS	火花塞	SPARK PLUG	2					
12	GB/T97.1-6	平垫圈 6	WASHER 6	7					
13	F15-07040104	气门导管	VALVE GUIDE BUSH	4					
14	F15-07010005	堵塞 1/4"	STOPPER 1/4"	2					

零部件名称:

曲轴箱

PARTS NAME:

CRANK CASE

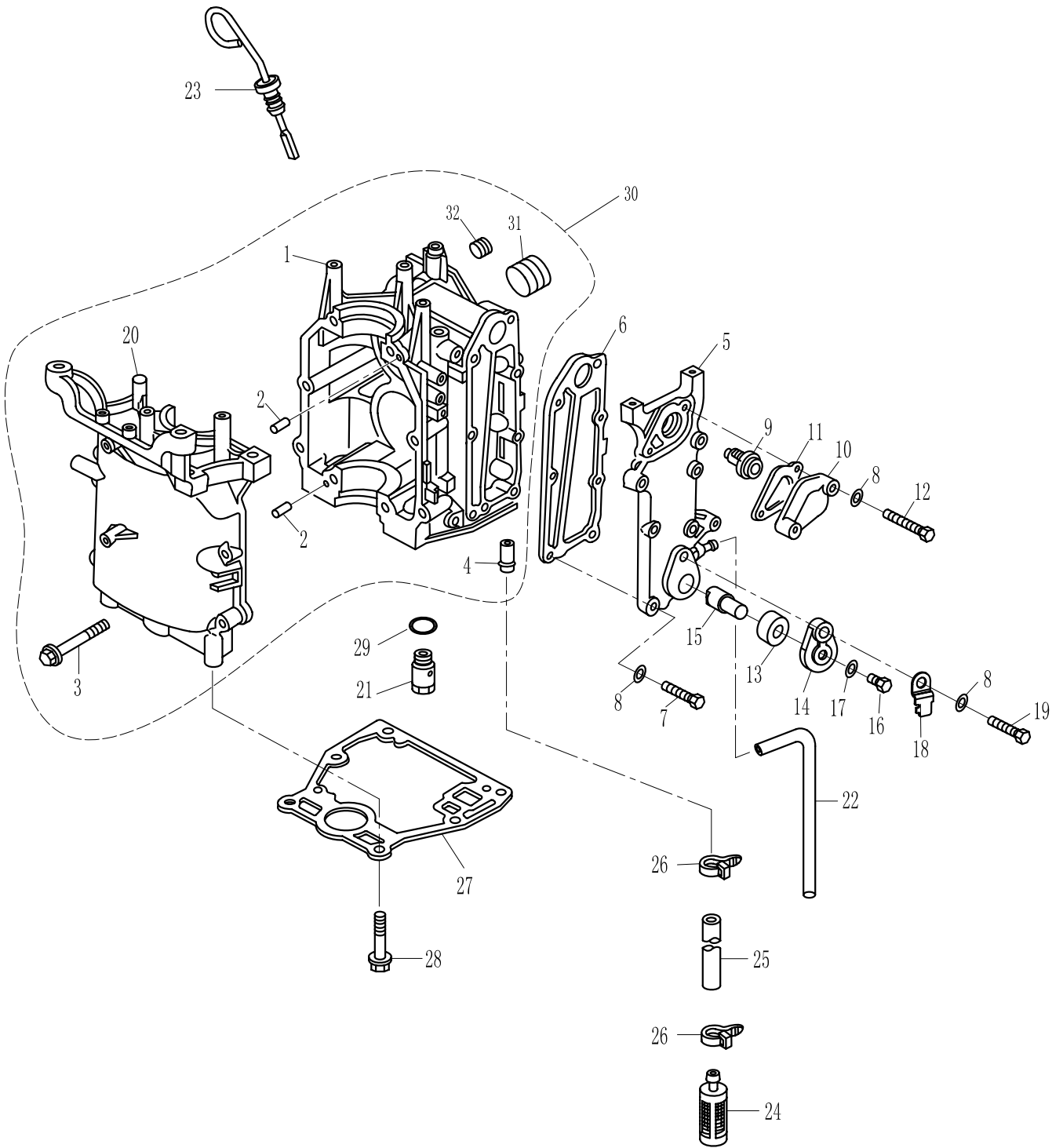

零部件名称:

燃油系统

PARTS NAME:

FUEL SYSTEM

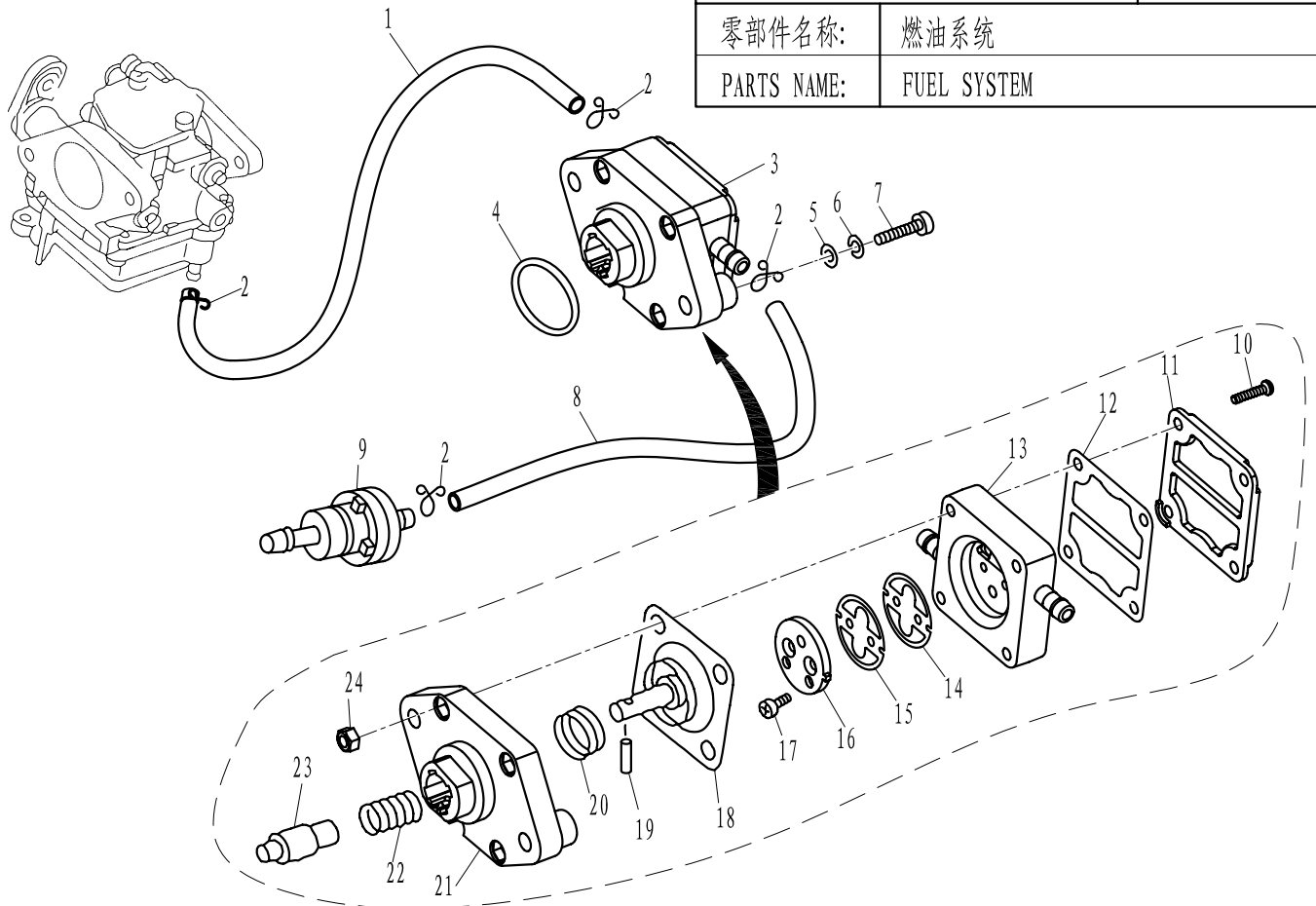

SN. 参照号码	PART NO. 零件编号	DESCRIPTION 零件名称(中文)	DESCRIPTION 零件名称(英文)	QTY 数量					REMARKS 备注
1	F8-05000015	油泵燃油管(出) $\phi 10 \times \phi 5 \times 280$	FUEL HOSE	1					
2	F4-04000030	油管夹簧B	CLIP "B", FUEL HOSE	4					
3	F8-05070000	燃油泵组件	FUEL PUMP ASSY	1					
4	JASO F404-A-24-021	燃油泵O型圈	O-RING, FUEL PUMP	1					
5	GB/T97.1-6	平垫圈 6	WASHER 6	2					
6	GB/T93-6	弹簧垫圈 6	SPRING-WASHER 6	2					
7	GB/T5783-M6X30	六角螺栓 M6X30	BOLT M6X30	2					
8	F8-05000014	油泵燃油管(进) $\phi 10 \times \phi 5 \times 180$	FUEL HOSE	1					
9	F4-05000300	燃油过滤器组件	FUEL FILTER ASSY	1					
10	GB/T823-M4X25	十字槽小盘头螺钉M4X25	SCREW, SMALL PAN HEAD M4X25	4					
11	F4-04090003	燃油泵盖	COVER, FUEL PUMP	1					
12	F4-04090004	上隔膜	TOP DIAPHRAGM	1					
13	F4-04090100A	燃油泵壳	SHELL, FUEL PUMP	1					
14	F4-04090001A	瓣膜B	VALVE "B"	1					
15	F4-04090002A	瓣膜A	VALVE "A"	1					
16	F4-04090003A	隔膜限位块	LIMITING BLOCK, SEPTUM	1					
17	GB/T819.2-M3X5	十字槽沉头螺钉M3X5	SCREW M3X5	2					
18	F4-04090100	隔膜组件	DIAPHRAGM ASSY	1					
19	GB/T309-3X12	滚针 $\phi 3 \times 12$	ROLLER NEEDLE $\phi 3 \times 12$	1					
20	F4-04090008	隔膜弹簧	SPRING, DIAPHRAGM	1					
21	F4-04090001	燃油泵座	SEAT, FUEL PUMP	1					
22	F4-04090007	柱塞弹簧	SPRING, PLUNGER	1					
23	F8-05070001	柱塞	PLUNGER	1					
24	GB/T6170-M4	螺母 M4	NUT M4	4					

零部件名称:

起动机

PARTS NAME:

STARTER

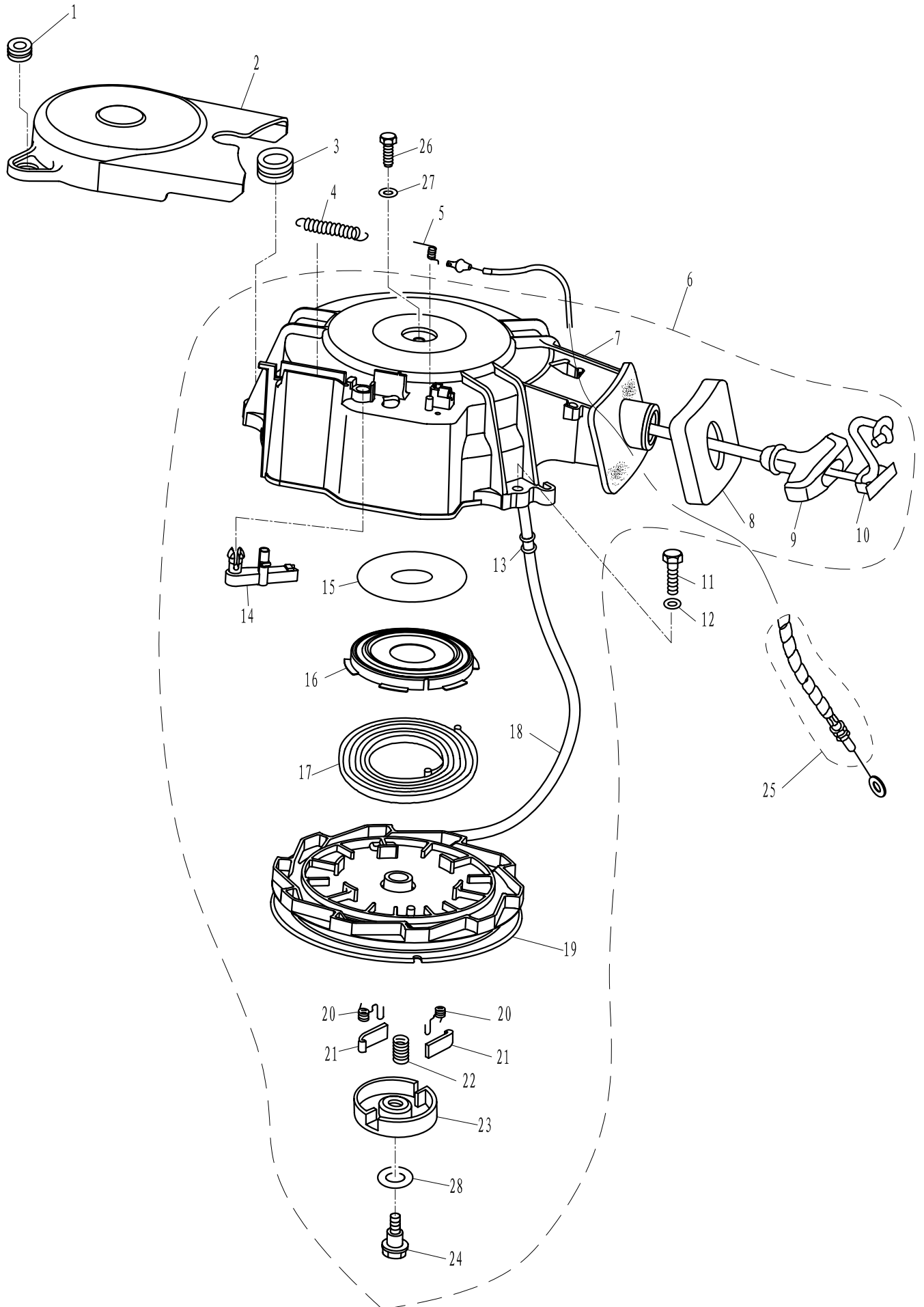

零部件名称:

顶罩组件

PARTS NAME:

TOP COWLING ASSY

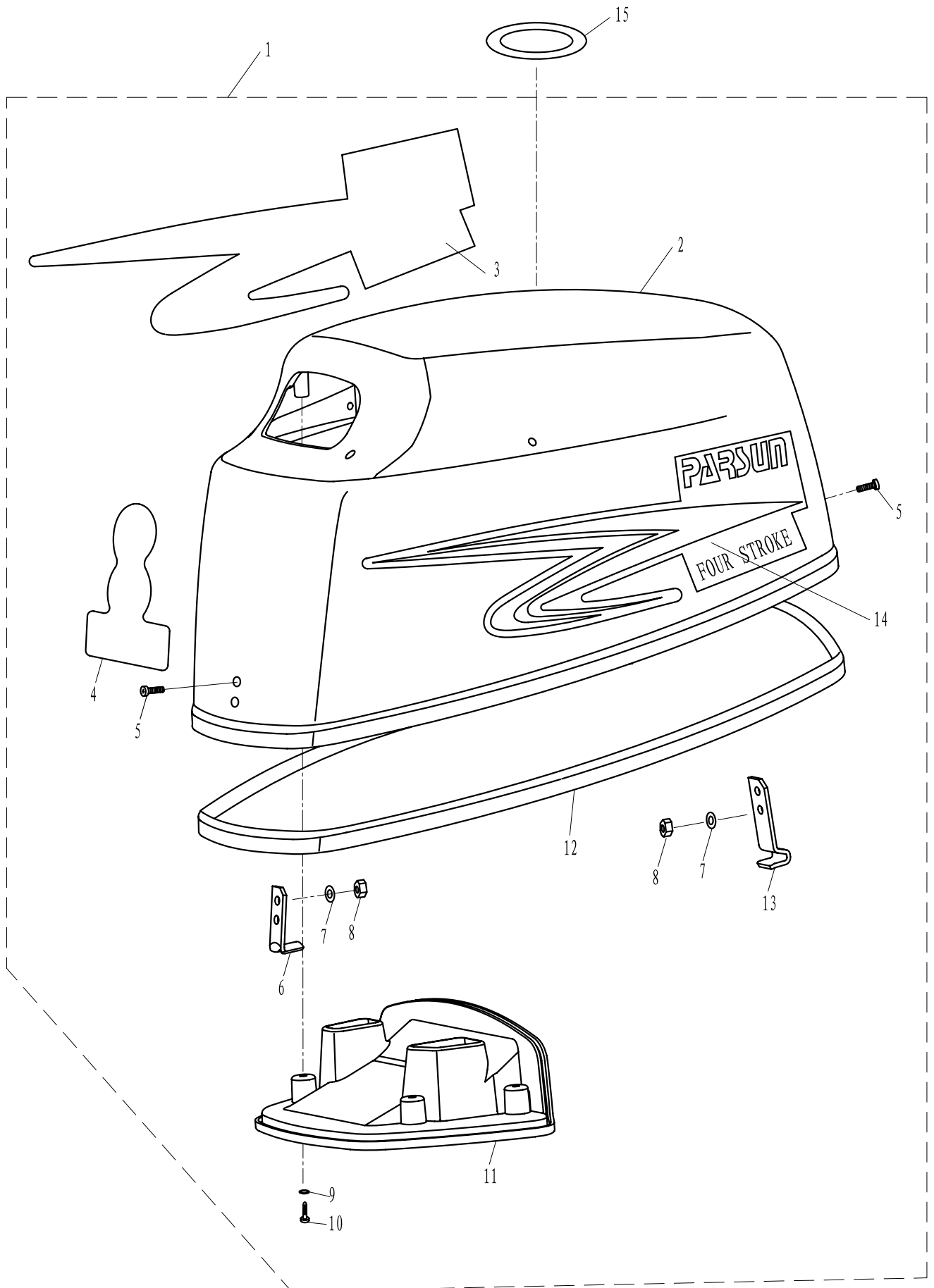

零部件名称: 气缸头总成(维修件)

PARTS NAME: CYLINDER HEAD ASSY (REPAIR KIT)

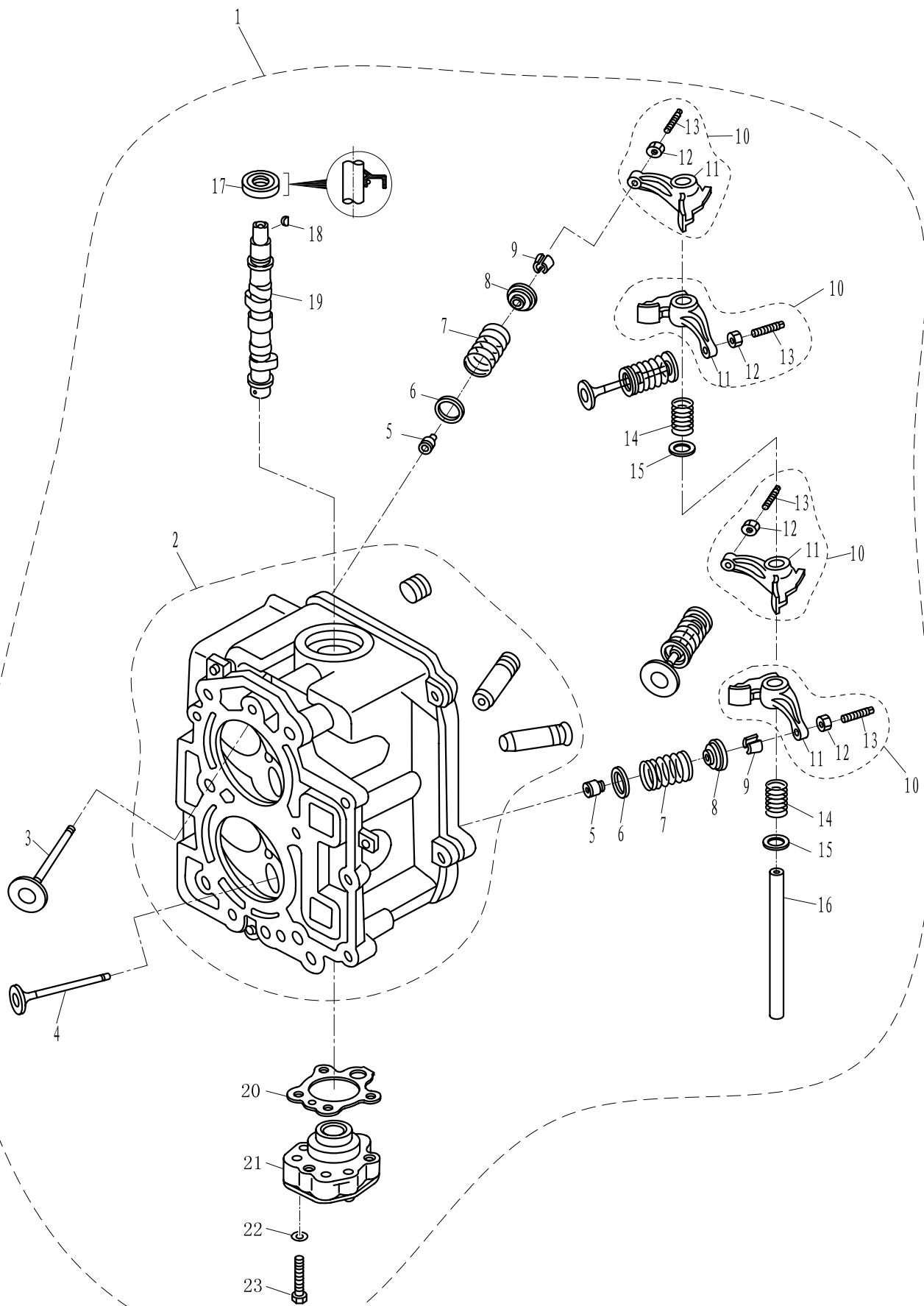

零部件名称:

发动机头总成

PARTS NAME:

ENGINE ASSY

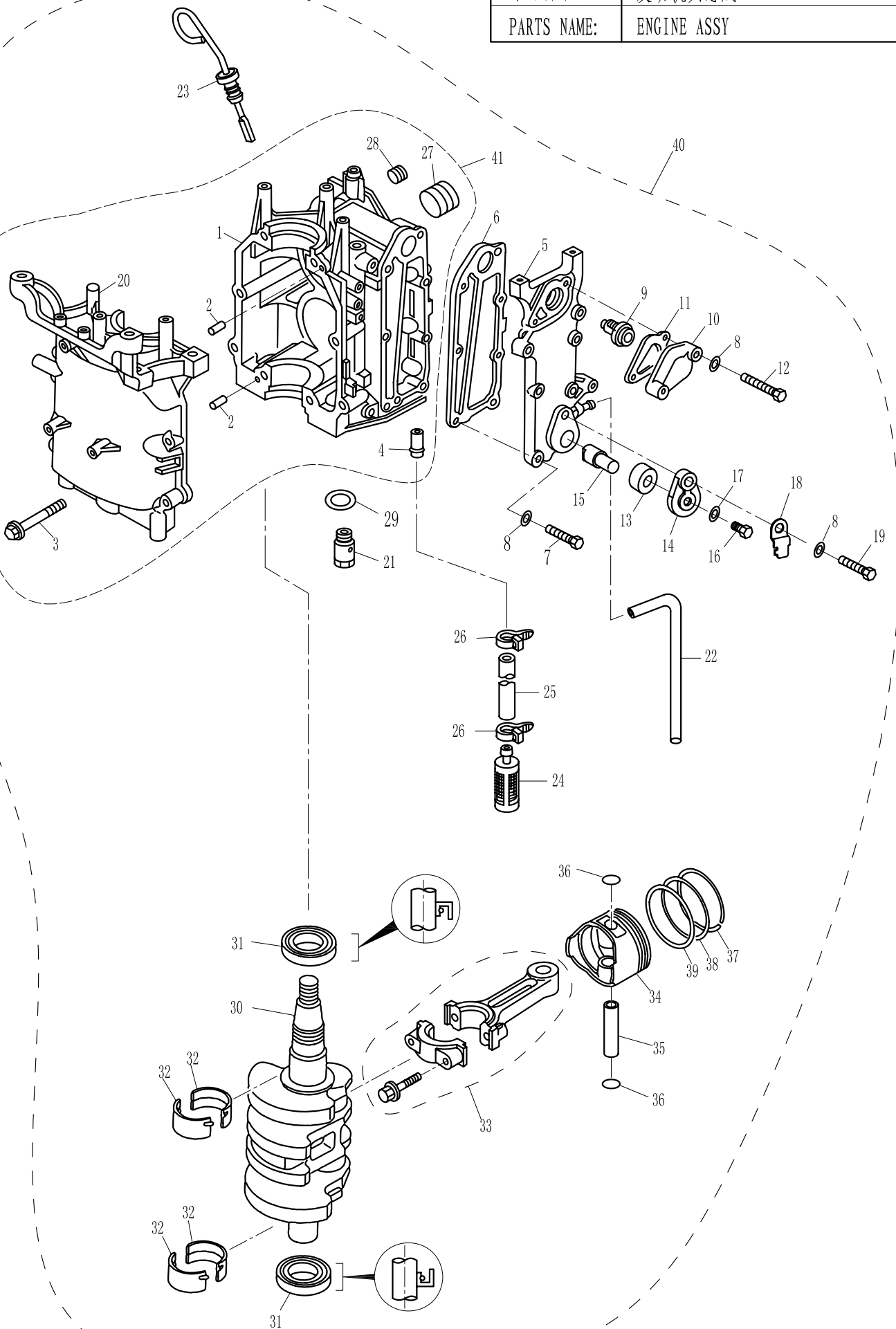

零部件名称: 附件 I (维修件)

PARTS NAME: APPENDIX I (REPAIR KIT)

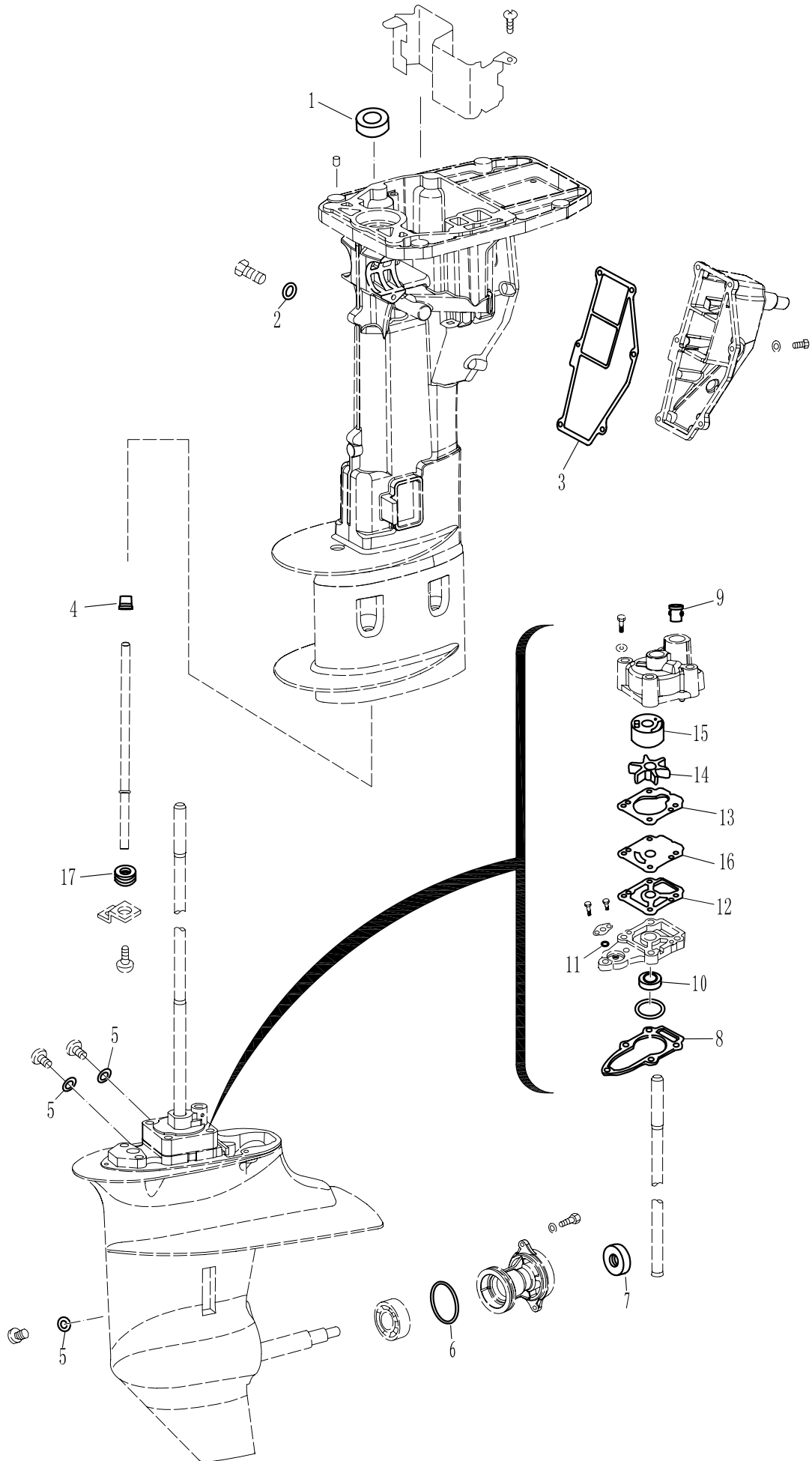

零部件名称: 附件 II (维修件)

PARTS NAME: APPENDIX II (REPAIR KIT)

